

▶ ACCUREX

Dedicated Outdoor Air Systems

Model XRV



COMPLETE TEMPERATURE AND HUMIDITY CONTROL

Accurex® industry-leading, energy-efficient Dedicated Outdoor Air Systems (DOAS) are the ideal solution for commercial kitchens that require a higher percentage of fully conditioned outside air. DOAS provide complete temperature and humidity control inside your kitchen or dining spaces and can provide space and cost savings by reducing the amount of equipment needed on your roof. Plus, Accurex offers a variety of supplementary options for additional energy efficiencies and application flexibility.

IDEAL APPLICATIONS:

- Open-Concept Kitchens
- Open Dining Rooms with High Occupancy
- Small Restaurants
- Larger Food Halls
- Food Halls
- Convenience Stores
- Fast Food Chains
- Ghost Kitchen Facilities
- Teaching Kitchens
- Event Venues

THE ACCUREX ADVANTAGE



FULLY CONDITIONS AIR FOR OPTIMUM EMPLOYEE AND PATRON COMFORT



MAY ALLOW FOR THE COMBINATION OF A UNITARY ROOFTOP UNIT AND THE MAKE-UP AIR, SAVING SPACE AND SIMPLIFYING INSTALLATION, ALL WHILE PROVIDING A SINGLE SOURCE OF CONTROL.



MICROPROCESSOR CONTROLLER WITH A WEB USER INTERFACE ALLOWS FOR COMPLETE CONTROL OF UNIT IN A SAFE AND ENERGY-EFFICIENT MANNER



50:1 BURNER TURNDOWN CAPABILITY ON INDIRECT GAS HEAT AND EITHER DIGITAL OR INVERTER SCROLL COMPRESSORS FOR COOLING TO PROVIDE COMFORT WITH PRECISE CONTROL



LOW-SOUND CONDENSER FANS ENSURE DOAS UNITS PROVIDE BOTH THERMAL AND AUDIBLE COMFORT



2-INCH DOUBLE-WALL WITH R16 FOAM INSULATION CONSTRUCTION FOR SUPERIOR QUALITY AND PERFORMANCE

SIMPLIFIED CONTROLS

MICROPROCESSOR

Standard on the XRV model, the controller is factory-programmed, wired and tested prior to shipment and can operate as a stand-alone device or integrate with a Building Management System (BMS).

- ✓ Operates the unit in a safe and energy-efficient manner while controlling temperature and humidity.
- ✓ Built-in furnace commissioning guide for streamlined start-up, saving time and money.

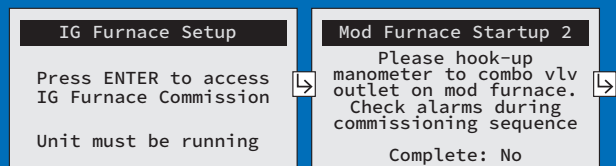

WEB USER INTERFACE (UI)

Microprocessor controller includes a user interface allowing the unit to be controlled from a web browser.

- ✓ A full graphic, specific to the unit selected, will allow for monitoring and control of the unit without a Building Management System (BMS).



- ✓ Includes full control display access, customizable data trending, and service contact information.

SAVE COSTS AND ENERGY

The Accurex DOAS unit provides options for additional cost savings and increased energy efficiency that meet or exceed Department of Energy minimum efficiency standards.

STANDARD LEAD INVERTER COMPRESSOR

Available from 3 to 100 tons and features:

- Improved part load efficiency
- Integrated Energy Efficiency Ratio (IEER) up to 23.7, with an average improvement over a digital scroll compressor of 15% to 20%
- Reduced sound levels
- Precise temperature and humidity control



AIR-SOURCE HEAT PUMP (ASHP)

This heating and cooling option is available from 3 to 30 tons and offers:

- High efficiency with an inverter compressor (standard feature)
- Lead EC outdoor fan motor (standard feature) for modulating head pressure control
- Coefficients of Performance (COP) ranging from 3-4, contributing to lower annual energy costs

Primary applications where ASHP is most efficient:

- Where gas heat may not be an option (example: West Coast)
- Any region with a mild winter climate

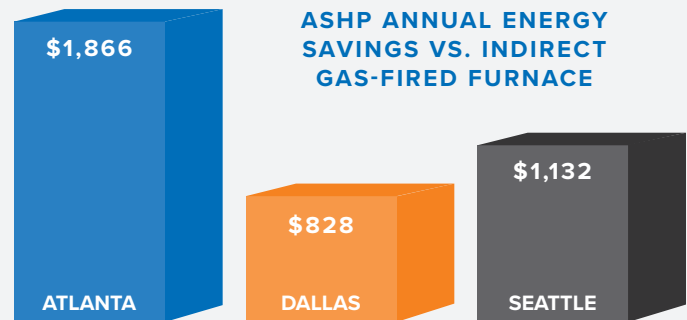

The chart illustrates the approximate energy cost savings of an ASHP over an indirect gas-fired furnace by region.

HIGH TURNDOWN FURNACE

Industry-leading technology for the tubular-style heat exchanger which is highly beneficial when large burners are utilized to prevent the unit from over or under-heating the space.

- Up to 50:1 furnace turndown for precise temperature control
- Less cycling during part-load conditions
- Commissioning sequence for easy start-up

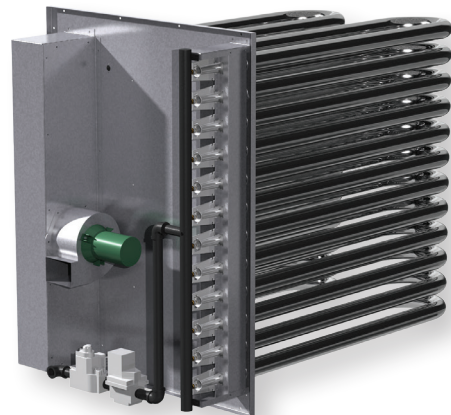

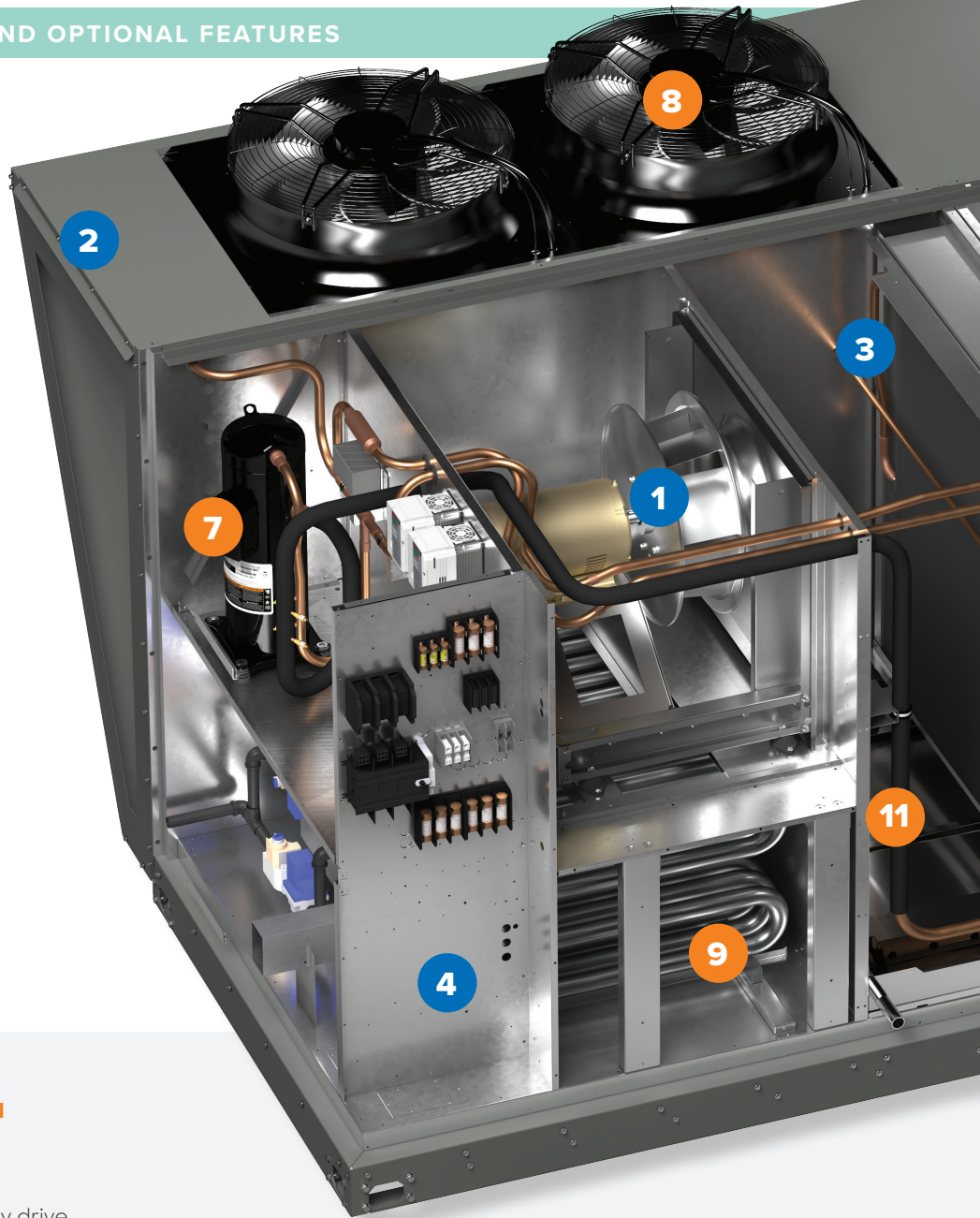

STANDARD FEATURE

OPTIONAL FEATURE

1 PLENUM SUPPLY/EXHAUST FAN

- Direct drive plenum fan
- Neoprene isolation
- Factory-provided variable frequency drive

2 CONSTRUCTION

- 2-inch double-wall construction unit housing and base
- R16 injected foam insulation thermally broken
- Standard coating with subsection to salt spray testing per ASTM-B117 and evaluated using ASTM-D714 and ASTM-D610 showing no observable signs of rust or blistering until reaching 2,500 hours

3 FILTERS

- Supply filters (pre-coil)
 - 2-inch MERV 8 or MERV 13
 - 4-inch MERV 8 or MERV 14
 - Combination of MERV 8 and MERV 13 or 14

4 CONTROL CENTER

- 24 VAC control voltage
- Control transformer
- Non-fused disconnect switch
- UL Listed, Recognized, or Classified electrical components
- Factory prewired for single point power connection
- Phase and brownout protection (PDX)

5 OUTDOOR AIR AND RECIRCULATED AIR DAMPERS

- Low leakage or insulated low leakage
- Modulating actuator

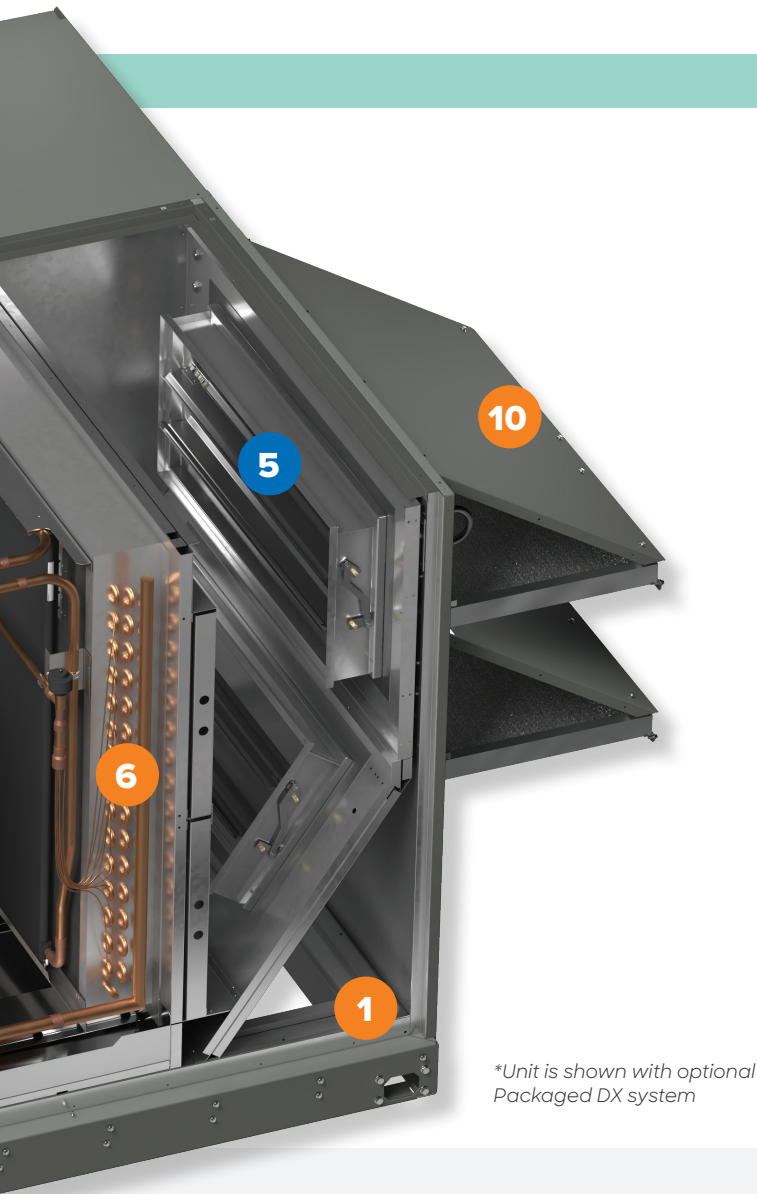

**Unit is shown with optional Packaged DX system*

OPTIONAL ACCESSORIES

- Building Pressure Sensor
- CO2 Sensor
- Condensate Overflow Switch
- Condenser Hail Guards
- Dirty Filter Sensor
- Duct Pressure Sensor
- Economizer Control
- Electrofin Coated Coils
- Microprocessor Remote Interface
- Outdoor, Supply, and Exhaust Airflow Monitor
- Roof Curbs
- Room Temperature Sensor
- Combination Room Temperature and Humidity Sensor
- Room Thermostat
- Service Lights
- Service Receptacle
- Smoke Detectors
- Economizer Fault Detection Diagnostics
- Ultraviolet Germicidal Irradiation (UVGI)
- Needlepoint Bipolar Ionization (NPBI®)

6 COOLING OPTIONS

- Packaged direct expansion (PDX)
 - Head pressure control with standard EC motor on the lead condenser fan or optional EC motor on all condenser fans
- Chilled water coil
- Mounted on a stainless steel drain pan
- Air-source heat pump
 - Standard features include inverter compressor and modulating head pressure control

7 DX COOLING COMPRESSOR

- Quiet operating hermetic, scroll-type
- 3 to 100 tons of mechanical cooling
- Standard inverter scroll compressor on lead circuit

8 DX COOLING CONDENSERS

- Low sound condenser fans

9 HEATING OPTIONS

- Indirect gas-fired furnace
 - Optional high turndown furnace (up to 50:1)
 - Stainless steel heat exchanger with a 25-year extended warranty
- Electric heater
 - Silicon controlled rectifier (SCR) control
- Hot water coil
- Air-source heat pump

10 WEATHERHOOD

- Aluminum mesh filters
- Wind-driven rain prevention

11 REHEAT

- Optional modulating hot gas reheat

Accurex offers a variety of solutions for noise reduction, unprecedented design flexibility and heating/cooling upgrades for operational efficiencies and enhanced guest experience.

NOISE REDUCTION

Accurex provides low-sound condenser fans as standard, offering an average sound power reduction of 5 to 8 decibels when compared to typical condenser fans.

- Low-sound swept blade condenser fans
- 2-inch R16 foam unit and base
- Compressor isolation
- Tested radiated sound data

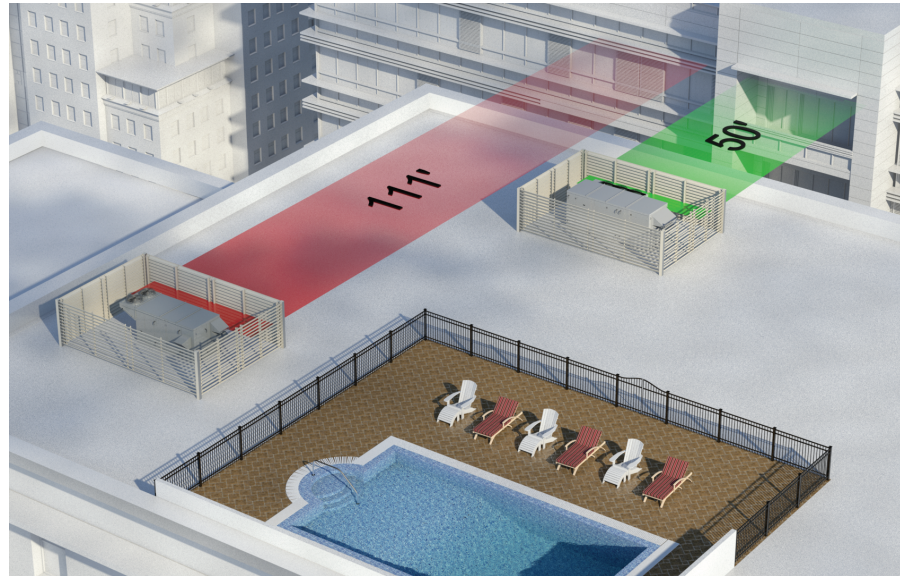

Accurex DOAS units can be placed closer to adjacent buildings and the public outside or inside and nearby buildings will be less affected by sound compared to the noise other rooftop units produce.

STATE-OF-THE-ART TESTING

If equipment is too loud or placed too closely to other buildings, corrective actions can be time consuming and costly. Our actual radiated sound data is tested in accordance with AMCA 320-07 in our state-of-the-art testing facility, the Robert C. Greenheck Innovation Center.

RADIATED SOUND LEVELS										
Plane	Octave Bands (Lw)								Plane Lw	Plane LwA
	1	2	3	4	5	6	7	8		
A	73	85	78	80	81	73	67	62	88	83
B	71	79	69	78	73	68	64	57	83	78
C	79	77	69	76	75	70	60	59	83	78
D	74	77	72	74	74	67	61	58	82	77
E	77	84	78	79	77	72	65	61	87	81
Total	83	89	82	85	84	78	71	67	93	87

Tests conducted in accordance with AMCA 320-07 - Laboratory Methods of Sound Testing of Fans Using Sound Intensity.

Free field measurement plane created one foot from unit on all sides and top tested at max capacity.

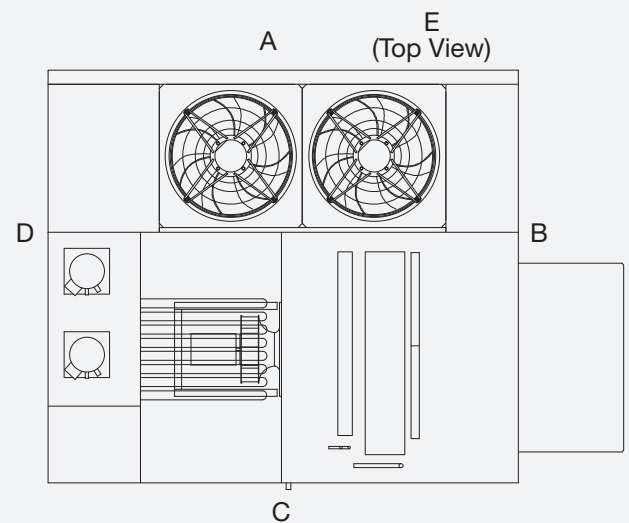

HORIZONTAL DUCT CONNECTIONS

An optional side or end return air intake and side discharge is available for installation flexibility.

- Common applications include indoor mounted, pad mounted, or rooftop mounted uses, reducing ductwork and eliminating the need for a tall, costly plenum curb.

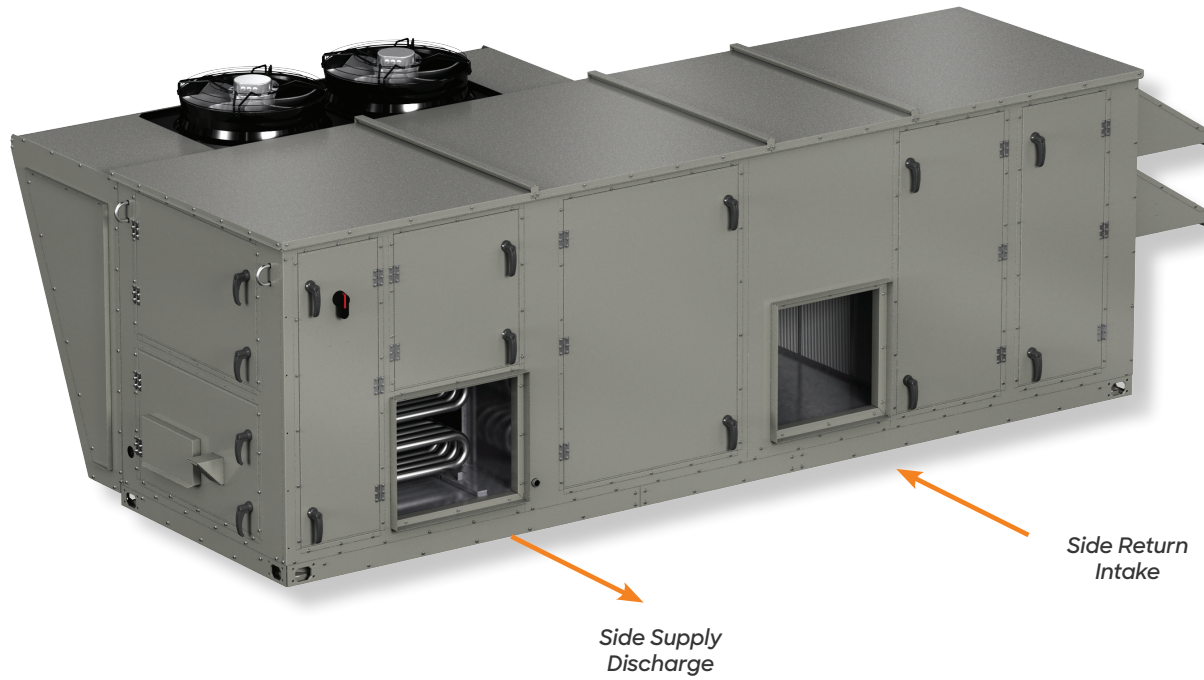

DOAS has been specifically engineered for commercial cooking applications that require higher percentages of outside air for ultimate comfort in kitchen and dining applications, offering precise temperature and humidity control.



Dehumidifies

Reduces and maintains humidity levels for increased occupancy comfort



Energy efficient

Meets or exceeds Department of Energy minimum efficiency standards



Easy installation

Factory mounted and wired microprocessor controller with easy set point adjustment and seamless integration to BMS



Economizer

Optional control sequence allowing for cool outdoor air to condition the space, in lieu of mechanical cooling



Demand control ventilation

Adjusts outdoor airflow to match building occupancy, reducing operational costs



Airflow monitoring

Stand-alone monitoring system to ensure proper ventilation and meet LEED requirements



Simple airflow adjustment

Direct drive backward-inclined plenum fans with factory-mounted VFDs provide precise airflow control via modulating fan speed, also eliminating belt losses and maintenance



Drain pan

Double-sloped stainless steel drain pan ensures that all condensate properly drains for the unit



Durable

2-inch double-wall construction with R16 foam insulation reduces thermal losses through the unit



Control system

Preconfigured and field adjustable controls that can be stand-alone or integrated into a building management system

PRODUCT CERTIFICATIONS

Accurex takes pride in offering a high-quality, reliable product. We invest our resources into designing, testing and manufacturing products to ensure customer satisfaction.



ETL Listed for electrical and overall unit safety. Every unit is tested at the factory before it is shipped to the jobsite.

SOLUTION DRIVEN

Noise and humidity can make for an uncomfortable atmosphere in your dining space. Accurex offers a variety of solutions to effectively alleviate these challenges. Here are some simple solutions for consideration.

<p>CHALLENGE</p> <p>CONDITIONING HIGH PERCENTAGE OUTDOOR AIR WITH MINIMAL ENERGY USAGE</p>	<p>CHALLENGE</p> <p>CONTROLLING OUTDOOR AIR VOLUME</p>	<p>CHALLENGE</p> <p>CRITICAL SOUND APPLICATIONS</p>
<div data-bbox="251 655 521 995" data-label="Image"> </div> <p data-bbox="224 1066 537 1094">ACCUREX SOLUTION</p> <ul data-bbox="152 1129 597 1598" style="list-style-type: none"> • High capacity (6-row) cooling coil • 2-inch R16 foam injected insulated unit and base • Inverter compressor (optional) • Modulating hot gas reheat coil (optional) • High turndown indirect gas-fired furnace (optional) • Modulating head pressure control (optional) • Air-source heat pump (optional) 	<div data-bbox="721 747 1015 999" data-label="Image"> </div> <p data-bbox="699 1066 1013 1094">ACCUREX SOLUTION</p> <ul data-bbox="628 1129 1073 1535" style="list-style-type: none"> • Low leakage dampers with modulating actuator • Factory-mounted and wired microprocessor controller • Energy-efficient control sequences • Direct drive plenum fan with factory-mounted VFD • Remote monitor and control from web-user interface 	<div data-bbox="1198 716 1484 999" data-label="Image"> </div> <p data-bbox="1177 1066 1490 1094">ACCUREX SOLUTION</p> <ul data-bbox="1105 1129 1529 1549" style="list-style-type: none"> • Low-sound condenser fans • Radiated sound data off five planes of unit tested at full load • 2-inch R16 foam injected insulated unit base • Compressor isolation • Inverter scroll at part load (optional) • Electronically commutated (EC) motor (optional)

MODEL XRV-20

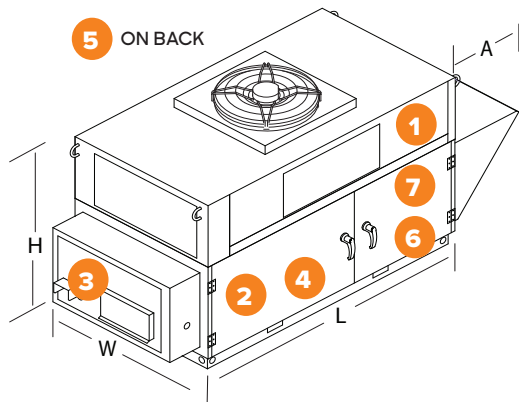

MODELS XRV-40, 85

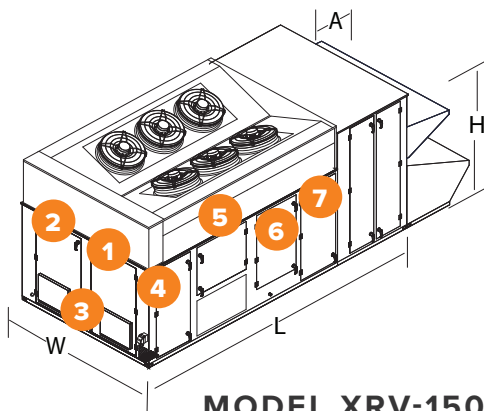
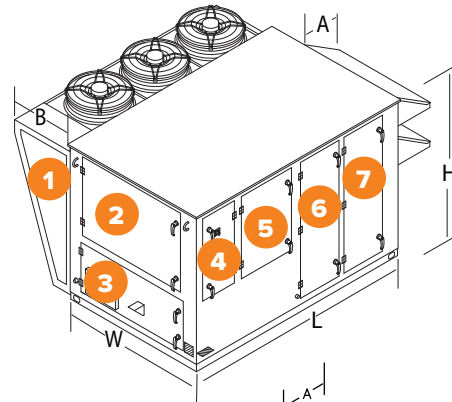

MODEL XRV-150

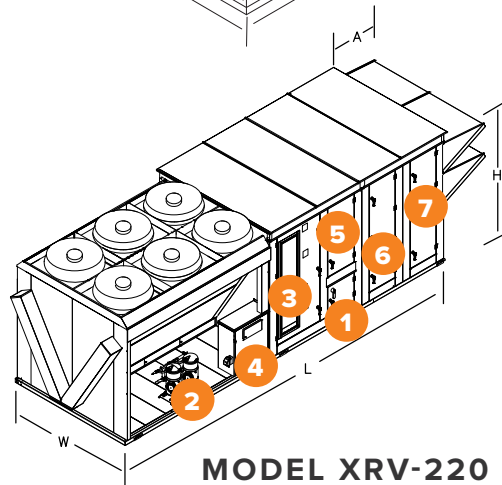

MODEL XRV-220

COMPONENT ACCESS

- 1 Inverter Drive (Optional for all models)
- 2 Compressor/ Electrical
- 3 Optional Gas Furnace/Optional Electric Heater
- 4 Electrical
- 5 Supply Blower
- 6 Coil
- 7 Filters

Unit Size	Nominal Tonnage (tons)	Height (H)	Width (W)	Length (L)	Intake (A)	Condensing Section (B)	Nominal Weight (lbs)	Outdoor Intake	Supply Discharge	Return Intake	Exhaust Discharge
XRV-20	3-7	58.1 ¹¹	44	82 ⁹ / 111.5 ^{7&9}	22.3	NA	1,225	End	Bottom or Side	Bottom, End ²	NA
XRV-40	5-15	59.3	52.5	98.6 ⁶ / 149.5 ⁷	22.1	30.1	3,150			Bottom, End ⁵ or Side ¹	End ³ or Side ¹
XRV-85	15-30	72.5	68.2	109 ⁶ / 163.2 ⁷	27.1	30.1	4,375			Bottom, End ⁵	End
XRV-150	25-70	101.3	98	155.2	39/48.4 ⁸	NA	7,625			Side ¹	End
XRV-150 EIS*	25-70	101.3	98	188	39/48.4 ⁸	NA	7,925				
	N/A			194.1	36.2	N/A	6,300				
XRV-220	50-80	101.8 ¹⁰	100.85 ¹⁰	295.11	36.2	101	10,325	Bottom	Bottom or End	Bottom or End	Side
	90-100			329.40	36.2	125.25	11,600				

All dimensions are shown in inches. Weight is shown in pounds and includes largest supply and exhaust fans, PDX with reheat, largest indirect gas-fired furnace, all dampers and largest energy wheel. Actual weights will vary based on the unit configuration.

¹ Only available with powered exhaust

² Only available without barometric relief

³ Only available with barometric relief

⁴ Only available without powered exhaust

⁵ Only available without powered exhaust and without barometric relief

⁶ Length with bottom or end return

⁷ Length with powered exhaust

⁸ Length with powered exhaust bumpout

⁹ Optional indirect gas-fired furnace bumpout length is additional 13.3 inches

¹⁰ With IG furnace configurations, an additional 22" stack is added to the unit height and 15.25" in width.

¹¹ With ASHP configuration, height is additional 18.6 inches.

* An EIS Unit means the return air intake is located on the side.

Packaged Direct Expansion			
Model	Airflow (SCFM)	Model	Airflow (SCFM)
XRV-20-3	1,100	XRV-85-30	5,200
XRV-20-4	1,450	XRV-150-25	8,300
XRV-20-5	1,700	XRV-150-30	9,400
XRV-20-6	1,600	XRV-150-40	10,000
XRV-20-7	1,700	XRV-150-50	10,800
XRV-40-5	1,900	XRV-150-60	11,000
XRV-40-7	1,900	XRV-150-70	11,500
XRV-40-10	2,600	XRV-220-50	11,800
XRV-40-12.5	2,300	XRV-220-60	13,000
XRV-40-15	3,100	XRV-220-70	15,200
XRV-85-15	3,800	XRV-220-80	15,500
XRV-85-17.5	3,800	XRV-220-90	16,200
XRV-85-20	4,600	XRV-220-100	15,400
XRV-85-25	4,800		

Air-Source Heat Pump	
Model	Airflow (SCFM)
XRV-20-3	1,200
XRV-20-4	1,300
XRV-20-5	1,500
XRV-20-6	1,750
XRV-20-7	1,700
XRV-40-5	2,600
XRV-40-7	2,700
XRV-40-10	3,700
XRV-40-12.5	4,300
XRV-40-15	3,900
XRV-85-15	4,300
XRV-85-17.5	4,400
XRV-85-20	6,300
XRV-85-25	7,200
XRV-85-30	7,100

Full load rating airflow per AHRI 210/240 or AHRI 340/360.
 PDX configured with ECM condenser fan and indirect gas heat.
 ASHP configured with ECM condenser fan and electric heat.

MODEL NUMBER CODE

The Model Number Code is designed to completely identify the unit. The correct code letters must be specified to designate the configurations and size.

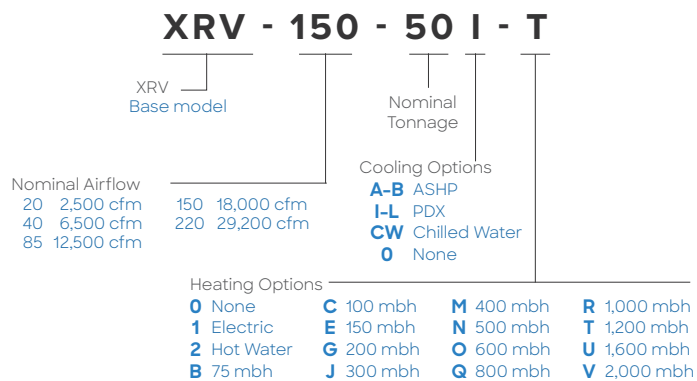

Discover how simple the Accurex way can be at [Accurex.com](https://www.accurex.com)

For more information, visit the
[XRV Product Page](#):



P.O. BOX 410 | SCHOFIELD, WI 54476
PHONE: 800.333.1400 | FAX: 715.241.6191
[ACCUREX.COM](https://www.accurex.com)

Our Commitment: As a result of our commitment to continuous improvement, Accurex reserves the right to change specifications without notice. Accurex product warranties are located on [accurex.com](https://www.accurex.com) within the product area tabs and in the Library under Warranties.

© 2026 Accurex, LLC
01.ACX.1021 R3 3-2026 FS