

Installation, Operation and Maintenance Manual

Please read and save these instructions for future reference. Read carefully before attempting to assemble, install, operate or maintain the product described. Protect yourself and others by observing all safety information. Failure to comply with these instructions will result in voiding of the product warranty and may result in personal injury and/or property damage.



General Safety Information

Only qualified personal should install this product. Personnel should have a clear understanding of these instructions and should be aware of general safety precautions. Improper installation can result in electric shock, possible injury due to coming in contact with moving parts, as well as other potential hazards. If more information is needed, contact a licensed professional engineer before moving forward.

1. Follow all local electrical and safety codes, as well as the National Electrical Code (NEC) and latest edition of the National Fire Protection Agency Standard for Ventilation Control and Fire Protection of Commercial Cooking Operations (NFPA 96). Follow the Canadian Electrical Code (CEC) and ULC-S650 if installing this product in Canada.
2. Do not allow the electrical components of this unit to come in contact with oil, grease, hot surfaces, water, or chemicals. Replace any cord/wiring immediately if damaged.
3. Verify the site can supply the necessary power for each fan and for the control panel.

WARNING

Electrical shock hazard. Can cause equipment damage, personal injury or death. Service must only be performed by personal that are knowledgeable in the operation of the equipment being controlled.

DANGER

Always disconnect power before working on or near the product. Lock and tag the disconnect switch or breaker to prevent accidental power up.

CAUTION

It is the responsibility of the installer to make sure both electrical and gas appliances shut down in the event of a fire or in the event of a power loss to the building when this sequence is required by the authority having jurisdiction.

Table of Contents

General Description	2
Receiving and Handling	2
Installation	
Main Enclosure Mounting	3
Switch Mounting	3
Temperature Sensor(s) - Hood Mounting	3-4
Duct Collar Mounting	4
Electrical Connections	
Power for Controls/Lights	6
Fire System Dry Contacts	6
Hood Lights	6
Motor Starter	7
Motor Starter or VFD in MUA	7
Fire Suppression Fire System Switch	8
Hood Temperature Sensors	9
Power for Shunt Trip	9
Additional Exhaust Dry Contacts	9
Additional Supply Dry Contacts	10
Fan Switch	10
Light Switch	10
Heat/Cool Switch	10
Field Connection Checklist	11
Digital Temperature Interlock Configuration	12-13
Testing	14
Operation	14
Troubleshooting	15
Maintenance	15
Frequently Asked Questions	16
Replacement Parts	16
Codes and Standards	16
Our Commitment	16

General Description

Description

The kitchen fan control center, or XFCC, is a pre-engineered package designed to control the operation of fans in a constant volume kitchen. The package consists of a cabinet encasing one or more fan motor starters interlocked together for on/off operation. Different fan, light and thermal switch combinations may be provided to operate the kitchen hood fan(s), light(s), and heating/cooling capabilities of the supply air. The control center as a standard is equipped with additional relays prewired to the fan starter(s). These additional relays are capable of turning on the kitchen exhaust and shutting down supply regardless of the present state of the fans via integration of a fire system microswitch with factory terminals. The control center can be equipped with temperature interlock, designed to automatically start kitchen fans and keep them running while heat is being generated from the cooking appliances. Hood systems should always be manually started before the cooking equipment is turned on, but if forgotten the interlock will safely trigger the fans to start once heat is detected. Other options are available.

Purpose

The purpose of the XFCC is to provide a complete control center equipped with fan motor starters. The control center provides a common connection point to interlock kitchen exhaust, supply, and hood lights with the hood's fire suppression system. The cabinet is pre-engineered with terminal blocks for most field wiring connections. The control center can also be equipped with interlock between the exhaust fans and cooking equipment, as to meet International Mechanical Code (IMC) 2024 Section 507.1.1. In this case, the system will utilize a temperature sensor in the exhaust duct collar or capture area in the hood to detect heat generated from cooking operations and automatically activate the exhaust fans if not already running.

Product Application

The XFCC is designed for both Type I and Type II (grease and non-grease) constant volume hood systems, where starters are needed to activate fans. The control center can operate both single and three phase fans. Accurex recommends using one XFCC per hood "zone" (activates all fans simultaneously). When temperature interlock is provided in this package, it is not to be used in conjunction with exhaust fire dampers.

Receiving and Handling

Receiving

Upon receiving the product, check to make sure all items are accounted for by referencing the bill of lading to ensure all items were received. Notify the carrier if any damage is noticed. The carrier will make notification on the delivery receipt acknowledging any damage to the product. All damage should be noted on all of the copies of the bill of lading which is countersigned by the delivering carrier. If damaged upon arrival, file a claim with the carrier. Any physical damage to the unit after acceptance is not the responsibility of the manufacturer.

Unpacking

Verify that all required parts and the correct quantity of each item have been received. If any items are missing, report shortages to your local representative to arrange for obtaining missing parts.

Storage

If this product must be stored prior to installation, it must be protected from dirt and moisture. Indoor storage is highly recommended.

NOTE

Improper storage which results in damage to the unit will void the warranty.

Handling

Make sure the equipment does not suffer any heavy vibration or knocks.



Installation

Main Enclosure Mounting

NOTE

Enclosure may be factory mounted in a hood or wall utility cabinet. If so, continue to next section.

NOTE

Minimum of 36" clearance recommended in front of control enclosure.

Locate an area with enough space to mount the main control enclosure and fasten to the wall. Use appropriate type fasteners depending on the mounting location. Enclosure size will be either 12", 18", or 25" long depending on what the panel was configured to control. See below for dimension data.

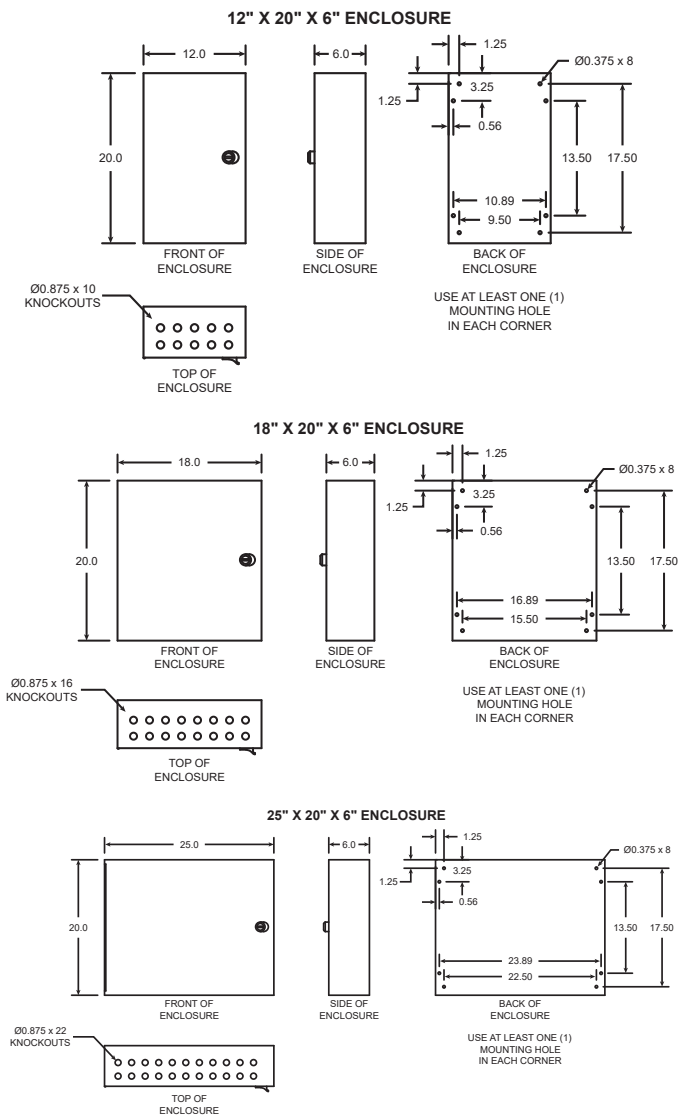

Switch Mounting

NOTE

If the switches were NOT shipped loose, provided in a separate junction box, continue to the next section.

Locate an area with enough space to mount the switches junction box and fasten to the wall.

Temperature Sensor(s) - Hood Mounting

NOTE

Temperature sensor(s) will be provided only if the digital temperature interlock option was configured/ordered with the unit. If it wasn't, continue to the next section.

Temperature sensor(s) may be factory installed. If so, continue to the next section.

1. Locate flat area(s) at the top interior of the hood in front of the filters, towards the front of the hood.

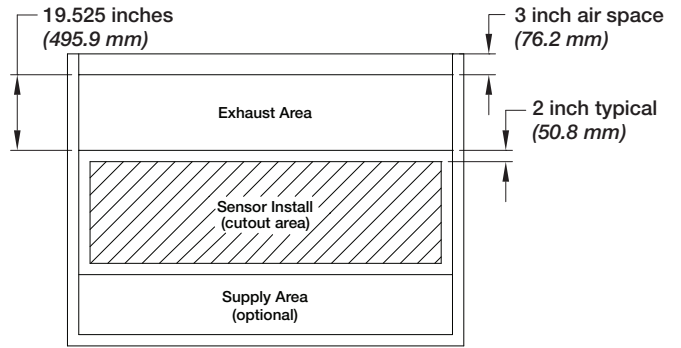

Top View of Exhaust Hood

2. Find a spot for the sensor in the flat space that will not interfere with the fire suppression nozzles and that is not within 12 inches (304.8 mm) of any light fixtures. Cut a 3/4 to 7/8-inch (19.0 to 22.2 mm) diameter hole in the flat spot of the capture tank.

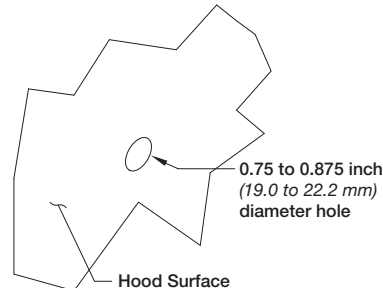

Temperature Sensor(s) - Hood Mounting, *continued*

- Place the J-box plate inside of the octagon extension ring and place over the hole.
- Disassemble the compression seal and place through hole and J-box plate as shown. Tighten the nut inside the octagon extension ring.

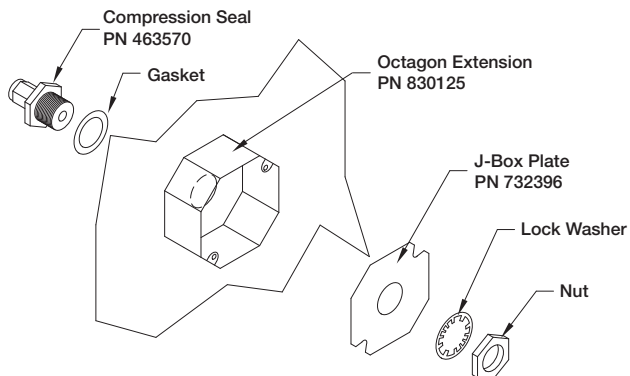

Exploded View (Components)

- Place the temperature sensor through the compression seal and tighten the compression fitting to 35 ft.-lbs. (47.5 Nm).

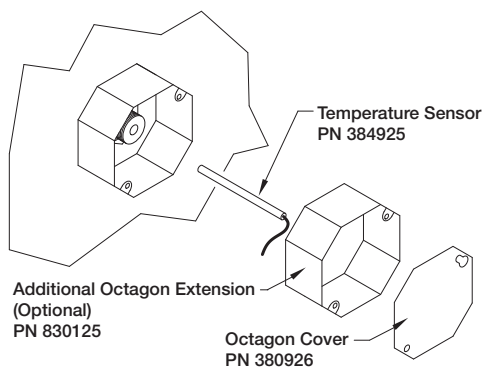

- Wire the sensor. Refer to Electrical Connections section for instructions on wiring the temperature sensor.
- Place octagon cover onto J-box and fasten it.

Temperature Sensor(s) - Duct Collar Mounting

- Locate the exhaust duct on top of the hood. Find a spot to mount the sensor where it will not interfere with fire suppression nozzles or other items installed in the ducts. If an exhaust fire damper is present in the hood exhaust collar, it must be removed prior to temperature sensor installation. A 3/4 to 7/8-inch (19.0 to 22.2 mm) diameter hole must be cut into the duct 2 inches (50.8 mm) above the hood top.

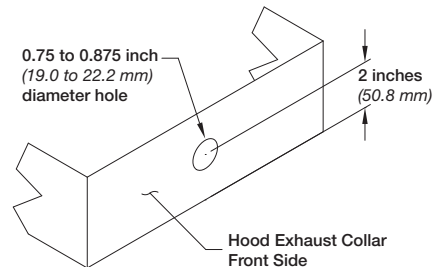

- Place the J-box plate inside of the octagon extension ring and place over the hole in the exhaust collar.
- Disassemble the compression seal and place through hole in duct collar and J-box plate as shown. Tighten the nut inside the octagon extension ring.

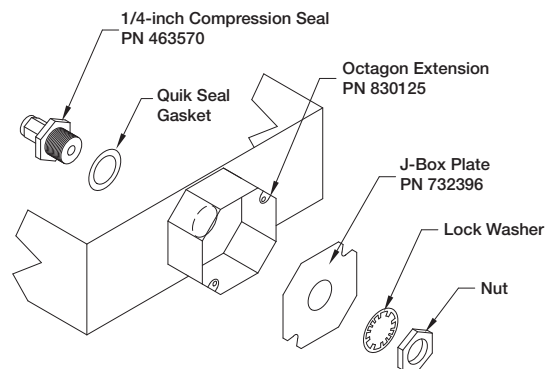

Exploded View (Components)

- Place the temperature sensor through the compression seal and tighten the compression fitting to 35 ft.-lbs. (47.5 Nm).

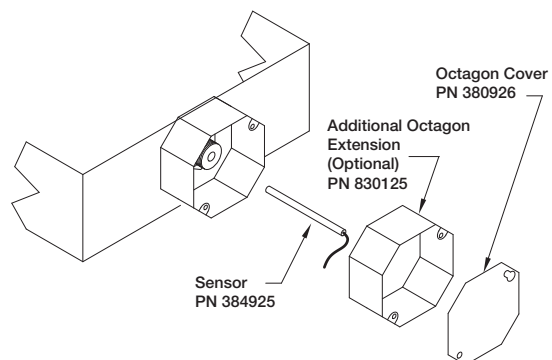

- Wire the sensor. Refer to Electrical Connections section for instructions on wiring the temperature sensor.
- Place octagon cover onto J-box and fasten it.



Electrical Connections

All field wiring requirements for the main enclosure will be shown on a sticker on the inside of the door of the panel.

Field connections may need to be connected to:

- Terminals blocks (open side), either on left side vertical din rail or top side horizontal din rail
- Direct to motor starters

NOTE

All wiring of electrical equipment must be done to meet NEC and local codes.

NOTE

It is recommended that shielded wire be used for all low voltage connections (24 volts or less) to prevent signal interference with other high voltage circuits.

NOTE

Typical size of low voltage wire used in the field should be 18-22ga, but voltage drop due wire length should be taken into consideration.

All 115 VAC field wiring (or higher) must be routed through hard or flex conduit. All low voltage field wiring should be plenum rated if not routed through conduit. Field wiring should not come in contact with the surface of the hood. To reduce the likelihood of electromagnetic disturbance, avoid routing high and low voltage cables in the same conduit.

TYP. KITCHEN FAN CONTROL CENTER PANEL LAYOUT

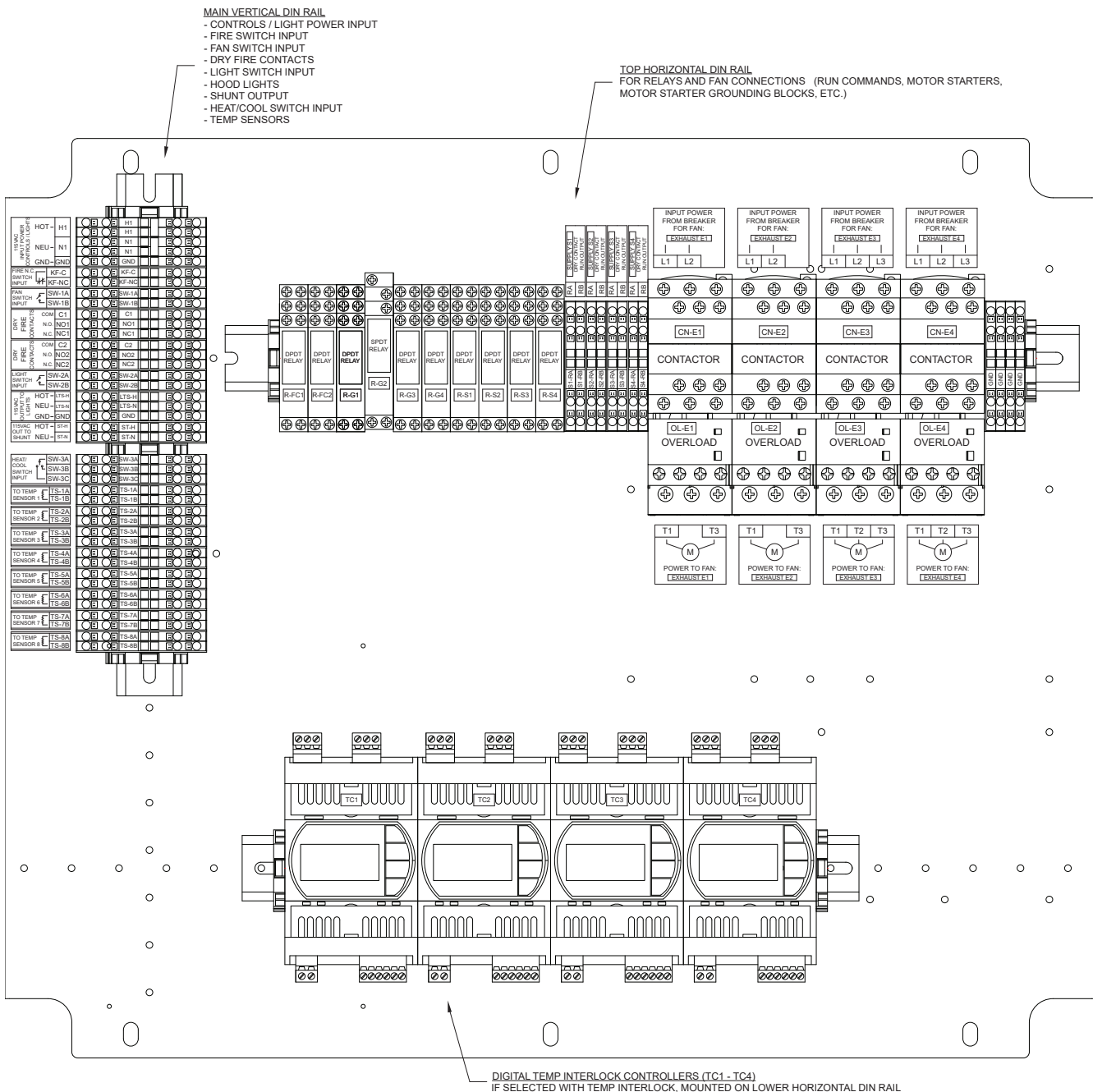

DIGITAL TEMP INTERLOCK CONTROLLERS (TC1 - TC4)
IF SELECTED WITH TEMP INTERLOCK, MOUNTED ON LOWER HORIZONTAL DIN RAIL



Power for Controls/Lights

115VAC 50/60Hz 1Phase. Land hot on terminal block H1, land neutral on terminal block N1, and land ground on terminal block GND. This should come from non-shunted 15A building breaker.

Example:

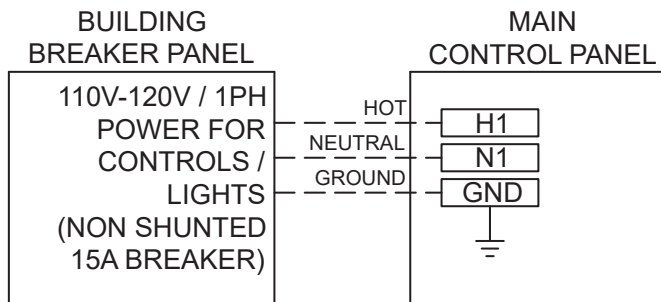

Fire System Dry Contacts

Fire system dry contacts are provided for controlling external devices, such as shunt trip breakers and/or appliance contactors that need to know when the fire system wet chemical has been released. These contacts will only function if fire system switch (common and normally-closed) is wired to terminal blocks KF-C and KF-NC in panel.

- Terminal block C1 - Common
- Terminal block NO1 – Normally Open
- Terminal block NC1 – Normally Closed

If provided with additional fire contacts, a second identical dry set is provided:

- Terminal block C2 - Common
- Terminal block NO2 – Normally Open
- Terminal block NC2 – Normally Closed

Example:

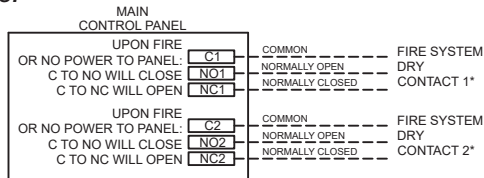

*FIRE SYSTEM DRY CONTACT WIRING EXAMPLES

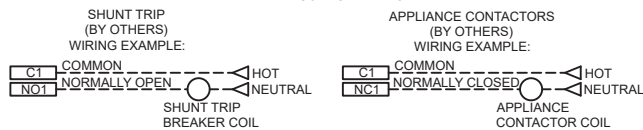

NOTE

Do not use these contacts for providing signals to the building fire alarm panel, as they will also switch state if power is ever lost to the control panel. Use separate spare fire system switch instead (mounted in fire suppression release).

NOTE

Do not use these contacts for shunt trip breakers and/or appliance contactors if the jobsite will experience frequent brownouts or blackouts. Use a spare fire system switch instead (mounted in the fire suppression release).

NOTE

Contacts rated for 8A and 250VAC max.

Hood Lights – If equipped

Hood lights (115VAC) should be wired in parallel and should be wired to terminal blocks LTS-H (hot), LTS-N (neutral), and GND (ground).

NOTE

Hood light load should not exceed 1200W.

NOTE

Hood lights may already be factory wired to a hood section's lights if control panel is mounted in a utility cabinet on the end of a hood.

Example:

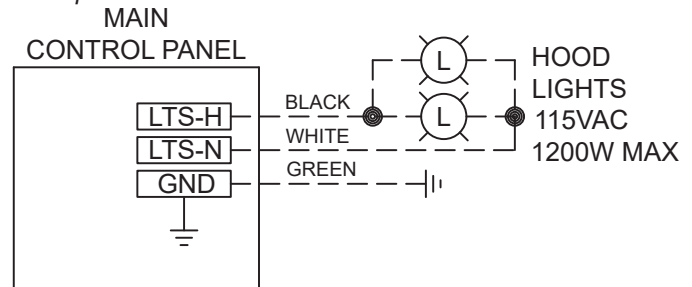

Motor Starter – If equipped

If motor starters are provided, input power from breaker should land directly on top of motor starter (L1 and L2 if single phase, or L1, L2, L3 if three phase). Power to fan should land directly on bottom of motor starter (T1 and T3 if single phase, or T1, T2, T3 if three phase). To help determine what fan gets wired to what motor starter, fan type and fan mark will be shown on the diagram.

Single Phase Example:

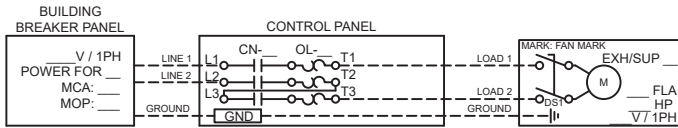

Three Phase Example:

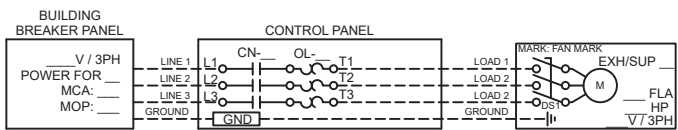

Motor Starter or VFD in MUA – If equipped

If controlling a Accurex constant volume MUA unit that's provided with a motor starter or VFD, the MUA power should be directly fed from building breaker to MUA unit disconnect. Low voltage wire should be run between control panel and MUA unit to control start/stop. Specifically, terminal blocks S_-RA and S_-RB in control panel should be connected to terminal blocks R and G in the MUA unit control center.

Example:

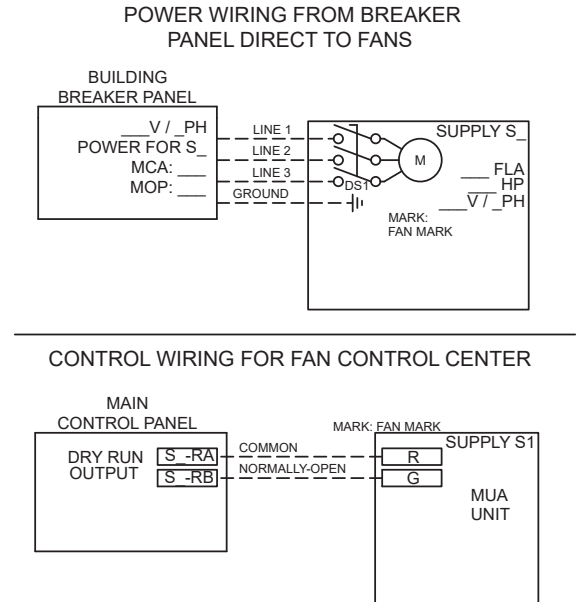

Fire Suppression Fire System Switch – If equipped

Type I hood systems may be equipped with a fire suppression system, which requires specific fan operation when a fire occurs. The fire suppression release will typically be equipped with either snap-action mechanical fire micro-switches, or a relay module provided with dry switch contacts. If using the fire suppression switch input, remove the jumper first before wiring in actual fire switch. Otherwise, leave the jumper installed if not using the fire suppression switch input.

If tying in one single fire suppression system to one control panel, tie common and normally-closed to terminal blocks KF-C and KF-NC in the control panel.

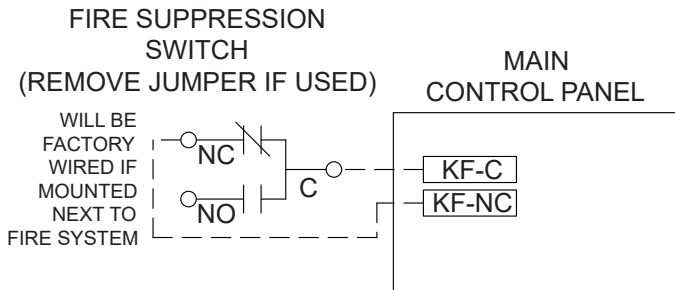

If tying in multiple fire suppression systems to one control panel, wire a series circuit loop between fire suppression systems, using normally closed contact on each fire suppression system switch.

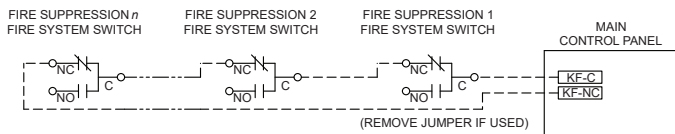

NOTE

KF-C and KF-NC should tie into DRY normally closed contact that OPENS during fire. DO NOT put any voltage onto these terminals from an external source, as KF-C already has 120V power on it that will flow through normally-closed fire switch back to KF-NC.

NOTE

This fire switch connection may already be made to the fire suppression system by the factory if panel is mounted in the same utility cabinet as the fire suppression release.



Hood Temperature Sensors – If equipped

Wire hood temp sensors back to individual TS-_A and TS-_B terminal blocks using 18ga – 22ga pair of low voltage wires (provided in field). Sensors are not polarity sensitive.

NOTE

Some hood temperature sensors may be wired by the factory if the control panel is mounted in a utility cabinet on the hood.

Example:

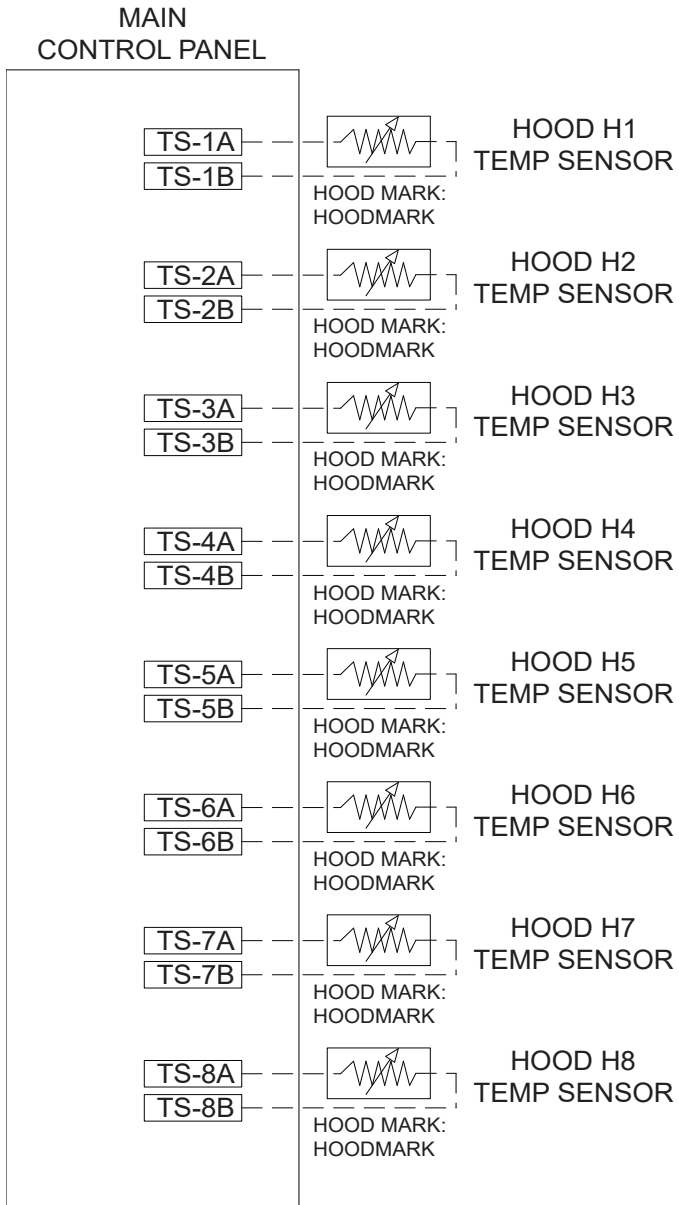

Power for Shunt Trip – If equipped

Terminals may be provided for signaling a field-provided shunt trip breaker coil to trip during a fire condition. This is a wet contact that will have 120VAC present during a fire condition. Wire shunt trip coil(s) to terminal blocks ST-H (hot) and ST-N (neutral).

Example:

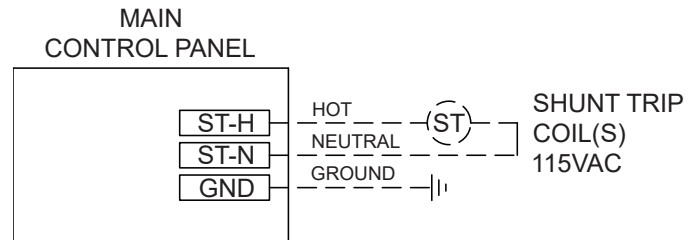

NOTE

During a loss of power to the control panel, when power is restored the shunt trip terminals will temporarily output 120VAC causing shunt trip breakers to trip.

Additional Exhaust Dry Contacts – If equipped

Additional exhaust dry contacts may be provided for controlling external devices like dampers, starters, VFDs, etc. These contacts will switch state when exhaust fans should be running.

First set:

- Terminal block C3 – Common
- Terminal block NO3 – Normally Open
- Terminal block NC3 – Normally Closed

Second set:

- Terminal block C4 – Common
- Terminal block NO4 – Normally Open
- Terminal block NC4 – Normally Closed

Example:

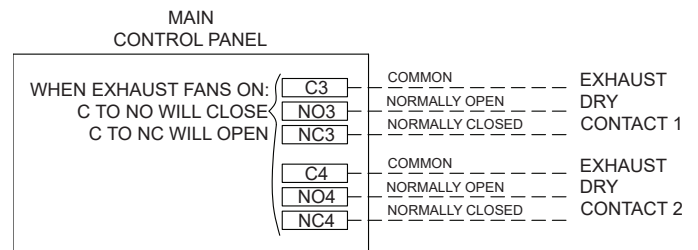

NOTE

Contacts rated for 8A and 250VAC max.

Additional Supply Dry Contacts – If equipped

Additional supply dry contacts may be provided for controlling external devices like dampers, starters, VFDs, etc. These contacts will switch state when supply fans should be running.

First set:

- Terminal block C5 – Common
- Terminal block NO5 – Normally Open
- Terminal block NC5 – Normally Closed

Second set:

- Terminal block C6 – Common
- Terminal block NO6 – Normally Open
- Terminal block NC6 – Normally Closed

Example:

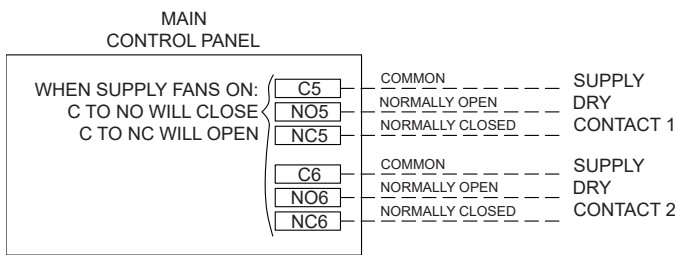

NOTE

Contacts rated for 8A and 250VAC max.

Fan Switch – If equipped

A switch may be supplied to operate fans. If equipped, the switch will either be:

1. Shipped loose for remote mounting
2. Mounted on the hood
3. Mounted on the hood utility cabinet
4. Mounted on a wall utility cabinet

If the fan switch and the XFCC are both mounted on the same hood, wiring to the fan switch will be done by the factory. If not, then field will need to wire the switch to terminal blocks SW-1A and SW-1B.

Example:

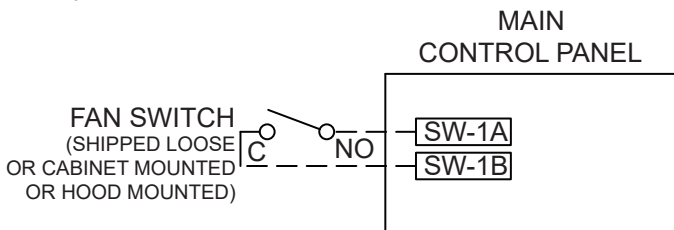

Light Switch – If equipped

A switch may be supplied to hood lights. If equipped, the switch will either be:

1. Shipped loose for remote mounting
2. Mounted on the hood
3. Mounted on the hood utility cabinet
4. Mounted on a wall utility cabinet

If the light switch and the XFCC are both mounted on the same hood, wiring to the light switch will be done by the factory. If not, then field will need to wire the switch to terminal blocks SW-2A and SW-2B.

Example:

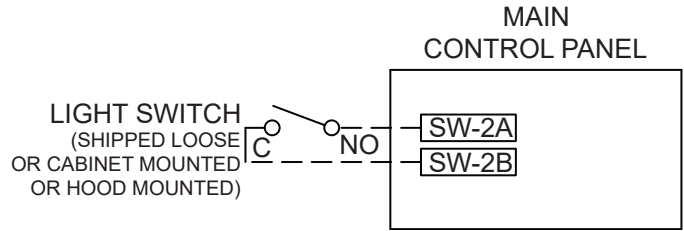

Heat/Cool Switch – If equipped

A switch may be supplied to enable/disable heat and/or cool function of the MUA. If equipped, the switch will either be:

1. Shipped loose for remote mounting
2. Mounted on the hood
3. Mounted on the hood utility cabinet
4. Mounted on a wall utility cabinet

If the heat/cool switch and the XFCC are both mounted on the same hood, wiring to the light switch will be done by the factory. If not, then field will need to wire the switch to terminal blocks SW-3A and SW-3B if heat only or cool only 2-position switch, and SW-3A, SW-3B, and SW-3C if heat/cool 3-position switch.

Example:

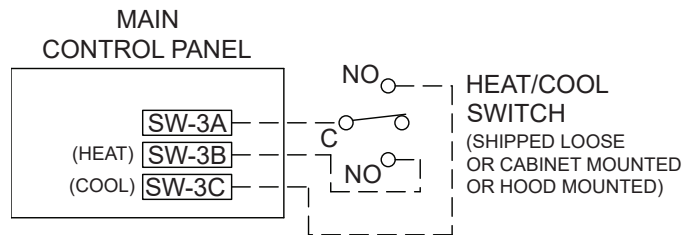

NOTE

See MUA unit diagram for where to terminate these SW-3 connections inside the MUA



Field Connection Checklist

Power for Controls/Lights

- 115 VAC 1Phase power for controls/lights (terminal blocks H1, N1, GND)

Fire System Dry Contacts

- Fire contact 1 for shunt trip/appliance contactor control (terminal blocks C1, NO1, NC1)
- Fire contact 2 for shunt trip/appliance contactor control (terminal blocks C2, NO2, NC2) – If equipped

Hood Lights – If equipped

- 115 VAC 1Phase to hood lights (terminal blocks LTS-H, LTS-N, GND)

Motor Starter – If equipped

- Line power to motor starter (terminals L1, L2 if 1 phase and L1, L2, L3 for 3 phase)
- Load power from motor starter (terminals T1, T3 if 1 phase and T1, T2, T3 for 3 phase)

Motor Starter or VFD in MUA – If equipped

- Line power direct to MUA unit disconnect
- Low voltage to R and G in MUA (terminal blocks S_₋RA and S_₋RB in fan control center)

Fire Suppression Fire System Switch – If equipped

- Common on switch to KF-C terminal block” and “Normally-closed on switch to KF-NC terminal block

Hood Temperature Sensors – If equipped

- Sensor 1 (TS-1A and TS-1B terminal blocks)

If more than one temperature sensor is used, wire the following if applicable:

- Sensor 2 (TS-2A and TS-2B terminal blocks)
- Sensor 3 (TS-3A and TS-3B terminal blocks)
- Sensor 4 (TS-4A and TS-4B terminal blocks)
- Sensor 5 (TS-5A and TS-5B terminal blocks)
- Sensor 6 (TS-6A and TS-6B terminal blocks)
- Sensor 7 (TS-7A and TS-7B terminal blocks)
- Sensor 8 (TS-8A and TS-8B terminal blocks)

Power for Shunt Trip– If equipped

- 115 VAC 1Phase to shunt trip coils (terminal blocks ST-H, ST-N, GND)

Additional Exhaust Dry Contacts – If equipped

- Exhaust dry contact 1 for controlling dampers, starters, VFDs, etc. (terminal blocks C3, NO3, NC3)
- Exhaust dry contact 2 for controlling dampers, starters, VFDs, etc. (terminal blocks C4, NO4, NC4)

Additional Supply Dry Contacts – If equipped

- Supply dry contact 1 for controlling dampers, starters, VFDs, etc. (terminal blocks C5, NO5, NC5)
- Supply dry contact 2 for controlling dampers, starters, VFDs, etc. (terminal blocks C6, NO6, NC6)

Fan Switch – If equipped

- Switch to land on SW-1A and SW-1B terminal blocks

Light Switch – If equipped

- Switch to land on SW-2A and SW-2B terminal blocks

Heat/Cool Switch – If equipped

- Switch to land on SW-3A and SW-3B terminal blocks if heat only or cool only 2-position switch
- Switch to land on SW-3A, SW-3B, and SW-3C terminal blocks if heat/cool/off 3-position switch

Digital Style Temperature Interlock Configuration

NOTE

This section only applicable if the XFCC is configured with digital temperature interlock option.

Pre-programmed, digital temperature controller(s) will be provided to monitor temperatures detected by sensor(s) and engage fan(s).

The fan(s) will start running when a temperature exceeds the set point (defaulted at 90°F) plus differential (defaulted at 10°F). Once the temperature drops back below the set point AND the fan(s) have been running for a minimum run time (defaulted at 5 minutes), the fan(s) will shut off.

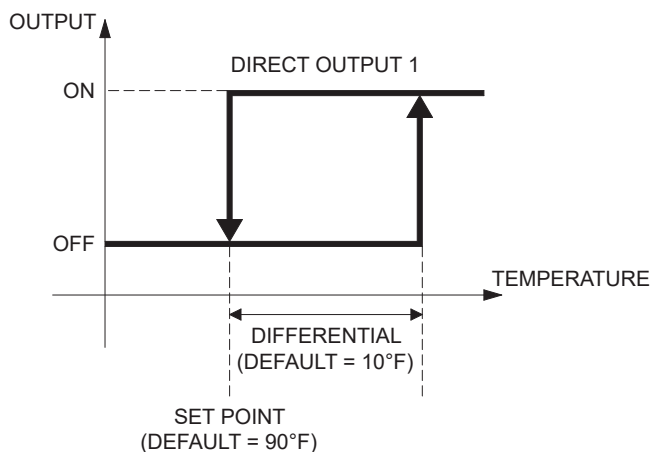

Calibration

Each controller is capable of monitoring individual sensors. There will be an individual set point for each sensor input. The temperature set point may need to be adjusted slightly depending on both ambient and cooking conditions. To adjust the set points on the controller, follow these instructions:

Carel 2-Sensor Controller

1. If setting set point 1 (St1), press . The display shows St1 and then the current value of St1.
If setting set point 2 (St2), press twice, slowly. The display shows St2 and then the current value of St2.
2. Press or to change the set point.
3. Press to confirm the new value of either St1 or St2.
4. Check system operation before making additional adjustments.

Show Sensor Values

Dwyer 3-Sensor Controller

1. Press . The current input will be displayed, alternating with the value:
b1 : probe 1
b2 : probe 2
di1 : digital input 1
di2 : digital input 2
St1 : set point 1
St2 : set point 2
2. Press or to elect the input to be displayed.
3. Press for three seconds to confirm.



Factory Parameters

NOTE

The controller is pre-programmed at the factory to operate based on how many sensors were selected. Adjustments (outside of the set point temperatures discussed in calibration section) should only be made under factory instruction. The list provided is for reference only.

Setting type P parameters

Type P parameters (frequent) are indicated by a code beginning with the letter P, followed by one or two numbers.

1. Press and hold the $\frac{\text{Prg}}{\text{mute}}$ button, after 3 seconds the display shows the firmware revision code (e.g. r2.1) is shown, after 5 seconds (in the event of alarms, first the buzzer muted) the code of the first type P modifiable parameter, P1.
2. Press \triangle or ∇ until reaching the desired parameter.
3. Press Set to display the associated value.
4. Increase or decrease the value using \triangle or ∇ respectively, until reaching the desired value.
5. Press Set to temporarily save the new value and return to the display of the parameter code.
6. Repeat operations from 4 to 5 to set other parameters.
7. To permanently save the new values of the parameters, press $\frac{\text{Prg}}{\text{mute}}$ for 5 seconds, thus exiting the parameter setting procedure.

Setting type c, d, F parameters

Type c, d or F (configuration) parameters are indicated by a code beginning with letters c, d, F respectively, followed by one or two numbers.

1. Press $\frac{\text{Prg}}{\text{mute}}$ and Set together for more than 5 seconds. The display shows the number 0.
2. Press \triangle or ∇ until displaying the password: 77
3. Confirm by pressing Set
4. If the value entered is correct, the first modifiable parameter c0 will be shown, otherwise the standard display will resume.
5. Press \triangle or ∇ until reaching the parameter to be modified.
6. Press Set to display the associated value.
7. Increase or decrease the value using \triangle or ∇ respectively, until reaching the desired value.
8. Press Set to temporarily save the new value and return to the display of the parameter code.
9. Repeat operations from 5 to 8 to set other parameters.
10. To permanently save the new values of the parameters, press $\frac{\text{Prg}}{\text{mute}}$ for 5 seconds, thus exiting the parameter setting procedure.

Carel Factory Parameters		
Parameter	Description	Factory Setting
St1	Setpoint 1	90
St2	Setpoint 2	90
c0	Operating Mode	1
P1	Set Point Differential	10
P2	Set Point Differential	10
P3	Dead Zone Differential	0
c6	Delay between two outputs	0
c9	Minimum relay on time	5
c10	Probe alarm output status 1	1
d10	Probe alarm output status 2	1
c11	Output Rotation	0
c13	Probe Type	3
P14	Probe 1 Calibration	0
P15	Probe 2 Calibration	0
c18	Unit of Measure	1
c19*	Function of probe 2	0 or 7

*Parameter c19 is factory set at 0. If controller is connected to two sensors, then the parameter is factory set at 7.

Testing

1. Turn the fan switch(es) on, then off to ensure proper fan operation before cooking equipment is started. Once this is verified, testing can proceed.
2. If applicable, turn the light switch(es) on, then off to ensure proper light operation in the hood. Once this is verified, testing can proceed.
3. Press and hold down the fire suppression switch connected to the XFCC and verify that the corresponding exhaust and/or supply fan(s) react appropriately when in the fire state. Verify all shunt trip breakers, alarms, and other components utilizing any of the spare relay contacts in the XFCC are activated properly.
4. With the fans turned off by the fan switch, turn on at least one piece of cooking equipment under the hood. The fans should automatically start within 5 to 10 minutes. If the fans take more than 15 minutes to start, decrease the temperature set point(s) on the temperature controller (see Digital Style Temperature Interlock Configuration, page 13).
5. If an adjustment was made in Step 4, repeat temperature test until fans automatically start within 15 minutes.
6. After verification of fan start-up, shut down cooking equipment. The fan switch should still be in the off position. Once cooking equipment has cooled below the set point, the fans will shut down.

CAUTION

If provided with temperature interlock, the sensors should never be exposed to direct flame. Exposing a sensor to direct flame may render the sensor inoperable and will void the warranty.

NOTE

During testing, if the XFCC is configured with temperature interlock and fans do not start automatically in the first 15 minutes of cooking equipment activation, manually start fans to avoid accidental fire system dump due to heat build-up.

Operation

1. Turn fans on and off using the fan switch.
2. **If XFCC is configured to control hood lights**, turn hood lights on and off using the light switch.
3. **If XFCC is configured with digital style temperature interlock**, it is normal for the fan(s) to remain running after the switch is turned off. The exhaust temperature controller will shut down fans after heat is no longer present under the hood and the temperature is below the set point. In the event that the cooking equipment is started without turning the fans on manually, the fans will turn on automatically and remain running with the presence of heat under the hood. Once the temperature is below the set point, the fans will shut down.



Troubleshooting

1. Fan(s) do not turn on automatically upon cooking equipment activation

- Confirm that the XFCC has been configured with temperature interlock.
- Check wiring to control panel. Sensors must be wired to the control panel separately.
- Temperature set point is too high, decrease set point.
- No power to fan(s), check breakers/starters/relays.

2. Controller(s) in XFCC display E01 or E02, and fan(s) will not shut off.

- E01 or E02 represent sensor errors.
- Disconnect each sensor from the system, and check resistance between the two wires on the sensor. At room temperature (77°F or 25°C), the sensor should read 1097.4 ohms.
- Check wiring connections between each sensor and control cabinet.

3. Fan(s) do not shut off.

- Fan switch must be in the off position.
- If the XFCC is configured with digital style temperature interlock, check the controller to determine if there is a sensor error of E01 and/ or E02. If yes, refer to the controller display error message, item 2 above.
- Cooking equipment is still hot, and the XFCC is configured with temperature interlock. Wait for the equipment to cool.
- Temperature set point for temperature interlock is set too low, increase set point.
- Check control circuit (fan starter) wiring.

4. Exhaust fan(s) will not shut off, and supply fan(s) will not turn on.

- Check hood for fire system dump.
- If no fire system dump has occurred, check fire system wiring between fire system microswitch and control panel.

5. Fan(s) do not turn on quick enough.

- Decrease temperature set point

Maintenance

Daily

If XFCC is configured with temperature interlock, clean thermostat or sensor with cloth and degreaser. Keep clean for best performance; can clean weekly depending upon grease accumulation.

Weekly

Depending on grease production and grease filter type in the hood, temperature thermostats or sensors can be cleaned weekly.

Seasonal

If XFCC is configured with temperature interlock, may have to change temperature settings if ambient kitchen temperatures fluctuate between summer and winter seasons.

Whom to call

Contact your local manufacturer's representative.

What to have ready for the call

Sales order, serial number and description of product.

Sales Order Number _____

Serial Number _____

Frequently Asked Questions Regarding Temperature Interlock

What temperature is the thermostat/temperature interlock set from the factory?

Digital style: 90°F set point + 10°F hysteresis

How do I determine if the XFCC is configured with digital style temperature interlock?

Digital style interlock uses 1/4-inch diameter sensor(s) mounted in either the hood capture area or exhaust collar(s). The XFCC will include a controller with a digital read out, capable of displaying different temperature values. Inspect the sensor diameter or look inside the XFCC for this digital-displaying controller.

Will the temperature interlock automatically start/stop the fans?

When connected properly to the fan starters the temperature interlock will automatically control the fans without input from the user. However, the intended use of the temperature interlock is as a back-up to manual control.

How many individual breakers does the XFCC require?

The number of individual breakers depends the number of fans controlled and options included in the XFCC. Each individual fan typically requires its own breaker. The XFCC main power and light power is on an individual breaker.

Can I still turn my fan on and off?

Yes, the temperature interlock is designed to operate with a typical on/off switch. The fan may not turn off immediately after turning the fan switch off, it will sense when the cooking operations have cooled and then turn off.

Replacement Parts

Part Number	Description
388266	Terminal Block, Single Pole, Din-rail mount, Wago 2202-1401
388269	Jumper, Terminal Block 2 Pole Wago 2002-402
383557	DPDT Relay Base Finder 9505SPA
383560	DPDT Relay Finder 40528120000 115 VAC DPDT Relay
Digital Style Temperature Interlock	
384925	Temperature Sensor (RTD) Dwyer 75102-00
856386	Carel Temperature Controller DN33W7HR20 Factory Programmed for 1 Sensor
856387	Carel Temperature Controller DN33W7HR20 Factory Programmed for 2 Sensor
830125	Extension, Octagon (drilled) SC55151-1/2 (380928)
732396	J-Box Plate
380926	Cover, Octagon Box SC#54-C-1RACO 722
463570	Evergreen Compression Seal 1/4-inch, #302

Codes and Standards Compliance

- UL 710 and UL 891
- National Fire Protection Association (NFPA 96)
- National Electrical Code (NEC)
- Canadian Electrical Code (CEC)

With Temperature Interlock Option Included:

- International Mechanical Code (IMC) 2024 Section 507.1.1

Our Commitment

As a result of our commitment to continuous improvement, Accurex reserves the right to change specifications without notice.

Product warranties can be found online at accurex.com, either on the specific product page or in the Warranty section of the website at Accurex.com/Resources/Warranty.



P.O. Box 410 Schofield, WI 54476
Phone: 800.333.1400 • Fax: 715.241.6191
Parts: 800.355.5354 • accurex.com