

Installation, Operation and Maintenance Manual

Please read and save these instructions for future reference. Read carefully before attempting to assemble, install, operate or maintain the product described. Protect yourself and others by observing all safety information. Failure to comply with these instructions will result in voiding of the product warranty and may result in personal injury and/or property damage.



The duct sump is a piece of duct designed to be installed at the low point(s) of long horizontal duct runs to collect and drain off moisture, liquid grease, etc. The Uniform Mechanical Code (UMC) and International Mechanical Code (IMC) specifies horizontal grease duct run must slope not less than one-fourth unit vertical in 12 units horizontal (2% slope) towards hood or toward the sump if less than 75 feet. If greater than 75 feet, the horizontal duct run must slope not less than one unit vertical in 12 units horizontal (8.3% slope). This product allows the more complex duct runs where sloping horizontal runs back to the hood are not feasible and stays within a workable horizontal clearance. The duct sump is controlled by an Auto Scrubber™ Control Panel.

Table of Contents

Receiving, Unpacking, Storage, Handling 2

System Components

Duct Sump 2

Auto Scrubber Control Panel (ASCP) 2

User Interface 2

Installation

Duct Sump 3

Auto Scrubber Control Panel (ASCP) 3

User Interface 3

Plumbing Connections 4

Typical Plumbing Connection Layout 4

Electrical Connections 5

Typical Electrical Connection Layout 5

Wash Operation 6

Wash Sequence of Operation 7

Duct Sump Detail 8

Typical Layout 8

Maintenance 9

Maintenance Log 10-11

Our Commitment Backcover

General Safety Information

Only qualified personnel should install this unit. Personnel should have a clear understanding of these instructions and should be aware of general safety precautions. Improper installation can result in grease fires as well as other potential hazards. If more information is needed, contact a licensed professional engineer before moving forward.

- Follow all local electrical and safety codes, as well as the National Electrical Code (NEC), and the National Fire Protection Agency (NFPA), where applicable. Follow the Canadian Electric Code (CEC) in Canada.
- Never open the access panel on the duct sump if the exhaust fan is on or if the sump is washing.

NOTE

Duct sumps are shipped with and controlled through the Auto Scrubber Control Panel (ASCP). The ASCP will be provided with a separate installation, operation, and maintenance manual. For more detailed information on the ASCP, please refer to manufacturer’s website.

Receiving

Upon receiving the product, check to make sure all items are accounted for by referencing the bill of lading to ensure all items were received. Notify the carrier if any damage is noticed. The carrier will make notification on the delivery receipt acknowledging any damage to the product. All damage should be noted on all of the copies of the bill of lading which is countersigned by the delivering carrier. If damaged upon arrival, file a claim with the carrier. Any physical damage to the unit after acceptance is not the responsibility of the manufacturer.

Unpacking

Verify that all required parts and the correct quantity of each item have been received. If any items are missing, report shortages to your local representative to arrange for obtaining missing parts.

Storage

If a duct sump must be stored prior to installation, it must be protected from dirt and moisture. Indoor storage is highly recommended.

Handling

Carefully move the sump to prevent denting or damaging.

System Components

Duct Sump

The duct sump consists of a piece of pitched ductwork fabricated from 16 gauge stainless steel designed to the specific duct size and equipped with a spray manifold, and drain with pre-flush and overflow. Access panel(s) are provided and designed per NFPA 96.

Auto Scrubber Control Panel (ASCP)

The control cabinet contains the water and electrical components, including the Programmable Logic Controller (PLC), that controls wash sequencing and operations. The control cabinet also includes the detergent reservoir, detergent pump, and other water piping.

User Interface

The user interface will be either a keypad with LCD screen or touch screen. It can be mounted on the Auto Scrubber control cabinet, hood or shipped loose for remote mounting. It will provide a WASH button (WASH ON/OFF with touch screen), and a means of turning on/off hood fans and lights, if applicable. It also includes system alarm notifications to alert of any faults on the system, such as low detergent alarm.

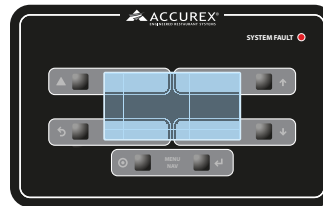

Keypad



Touch Screen



Installation

Duct Sump

1. Position duct sump inline with the horizontal ductwork. Per IMC and UMC, the horizontal duct run must slope not less than one-fourth unit vertical in 12 units horizontal (2% slope) towards hood or toward the sump if less than 75 feet (22.8 m). If greater than 75 feet (22.8 m), the horizontal duct run must slope not less than one unit vertical in 12 units horizontal (8.3% slope). Per NFPA 96, duct sump along with ductwork has to be at least 18 inches (45.7 cm) to combustible material, 3 inches (7.6 cm) to limited combustible material, and 0 inches (0 cm) to non-combustible material. Make sure these and all local code requirements will be met before welding.

NOTE

Duct sump is not intended to be mounted outdoors.

2. Weld ductwork on inlet and outlet of duct sump. Welds need to be liquid-tight, continuous and external. One inch flanges are provided at the inlet and outlet collars. Acceptable duct-to-duct connections (per NFPA 96) include flange with edge weld or flange with filled weld. Butt-welded connections are not permitted. Consult NFPA 96 for details.

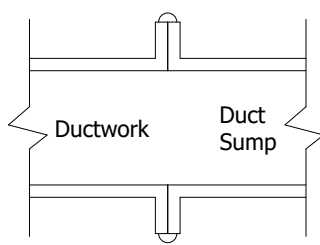

Flange with Edge Weld

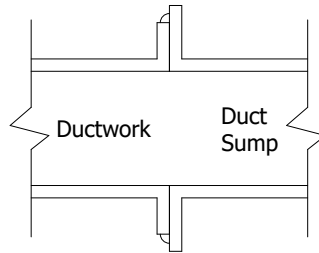

Flange with Filled Weld

3. After welded in place, make all plumbing connections, refer to page 4.

NOTE

If ductwork and duct sump need to be fire wrapped, make sure access panel(s) (if equipped) on the duct sump can still be removed. If ductwork and duct sump are to be enclosed in a field-applied grease duct enclosure, make sure the enclosure also doesn't block these access panel(s).

ASCP and User Interface

Consult ASCP Installation, Operation, and Maintenance manual for installation information.

Plumbing Connections

1. Install factory provided backflow preventer (shipped loose with ASCP) and drain connection per local code.

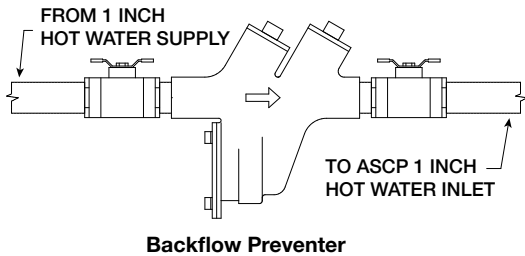

2. Bring 1-inch (25.4 mm) hot water supply line to the backflow preventer.
3. Plumb 1-inch (25.4 mm) line from the outlet of the backflow preventer to the hot water inlet connection in the ASCP.

4. Plumb 1-inch (25.4 mm) line out of ASCP hot water outlet connection to (each) duct sump solenoid valve (factory provided valve, shipped loose) and Auto Scrubber hood (if applicable). Each duct sump valve is a 3/4-inch valve; a reducer (by others) will be needed.
5. Plumb 3/4-inch (19.05 mm) line from solenoid valve to inlet fitting on the side of the corresponding duct sump.
6. Plumb 1-1/2 inch (38.1 mm) drain from bottom of sump to a grease trap in the building. Consult local code for grease trap requirements.

NOTE

- Hot water temperature should be 140°F (60°C)
- While the duct sump is washing, water pressure in the control panel should be between 40 and 70 PSI (275.8 and 482.6 kPa).

Typical Plumbing Connection Layout

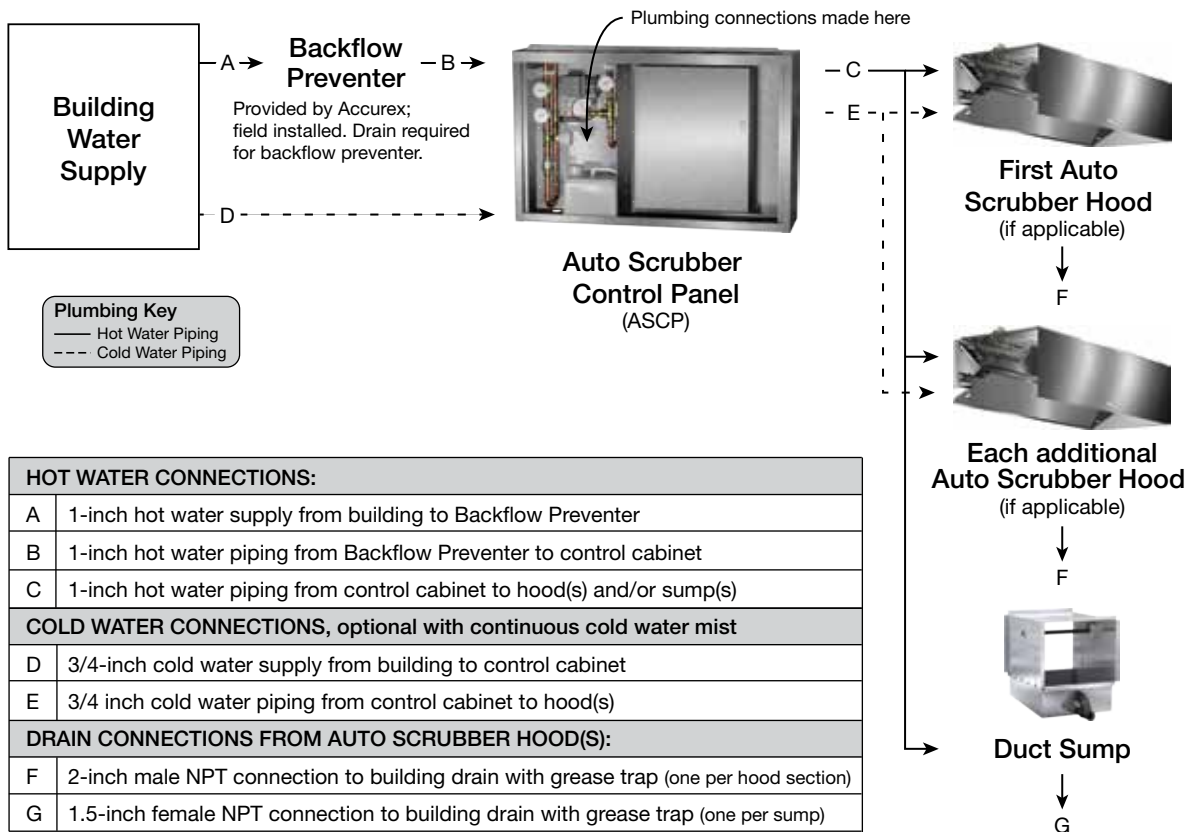

Electrical Connections

NOTE

All wiring of electrical equipment must be done to meet NEC and local codes.

NOTE

It is recommended that shielded wire be used for all low voltage connections (24V or less) to prevent signal interference with other high voltage circuits.

NOTE

All 115 VAC field wiring (or higher) must be high temperature rated and must be routed through hard or flex conduit. All low voltage field wiring should be plenum rated if not routed through conduit. To reduce the likelihood of electromagnetic disturbance, avoid routing high and low voltage cables in the same conduit.

Consult ASCP Installation, Operation, and Maintenance manual for complete wiring instructions for the ASCP control panel.

Duct Sump Solenoids – if equipped

Each duct sump will be provided (shipped loose) with a 3/4-inch solenoid valve. Each valve will need to be wired back to the ASCP panel. Solenoids are 24 VAC (use 18 gauge, stranded wire).

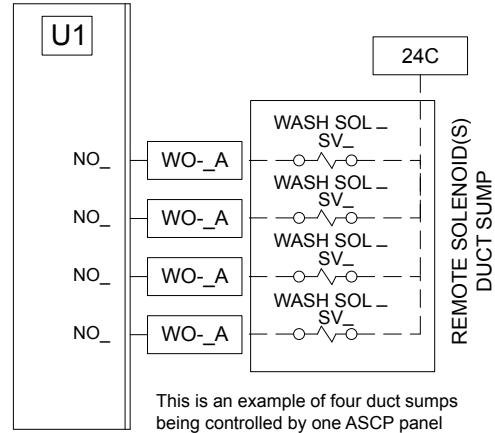

Typical Electrical Connection Layout

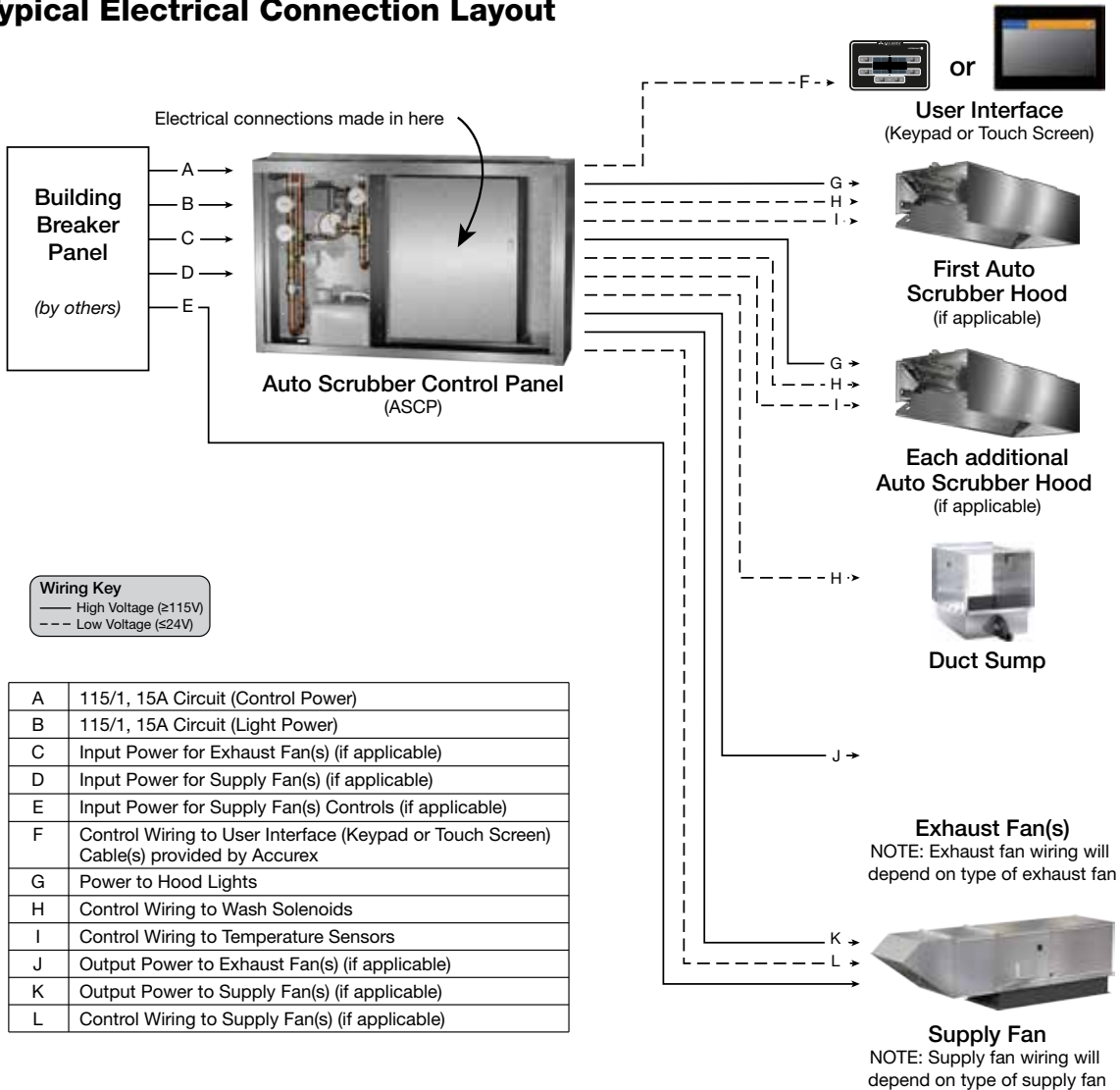

Wash Operation

For ASCP controller menu navigation, user interface navigation, and initial start-up procedures, see ASCP Installation, Operation, and Maintenance manual.

A duct sump wash can be initiated through a number of different options.

Wash by Button (Factory default = **ON**): A wash can be initiated through pressing either the “WASH” button (if equipped with a keypad) or by pressing “WASH ON/OFF” icon (if equipped with a touch screen).

Wash by Digital Input (Factory default = **OFF**): A wash can be initiated through engaging a configured digital input on controller. For the correct terminals to wire this digital input, please reference the Auto Scrubber Control Panel wiring diagram.

Wash by BMS Interface (Factory default = **OFF**): A wash can be initiated daily at a specific time. If this option is enabled, this time can be field adjusted within the controller and touch screen, if equipped.

Wash by Scheduler (Factory default = **OFF**): A wash can be initiated daily at a specific time. If this option is enabled, this time can be field adjusted within the controller and touch screen, if equipped.

When a wash cycle has been initialized, all connected Auto Scrubber hoods will individually be washed first, then the duct sumps will be washed in order starting with Duct Sump 1. If Auto Scrubber hoods are also connected to the system, they will be individually washed first (before the sumps).

A wash cycle can be stopped at any time by pressing the “WASH” button (if equipped with a keypad) or by the “WASH ON/OFF” icon (if equipped with a touch screen).

When duct sumps are washing, fans cannot run, unless:

- A kitchen fire is detected
- A sensor linked to any Auto Scrubber hood fails, or any temperature sensor exceeds the temperature interlock on setpoint
- If the Auto Scrubber control panel is equipped with no fan controls (ASCP-W) and the fan input is triggered



Wash Sequence of Operation

NOTE

The previously stated items regarding ending a wash cycle/skipping a hood wash still apply. Please use this in conjunction with the information found in Wash Operation section found on page 6.

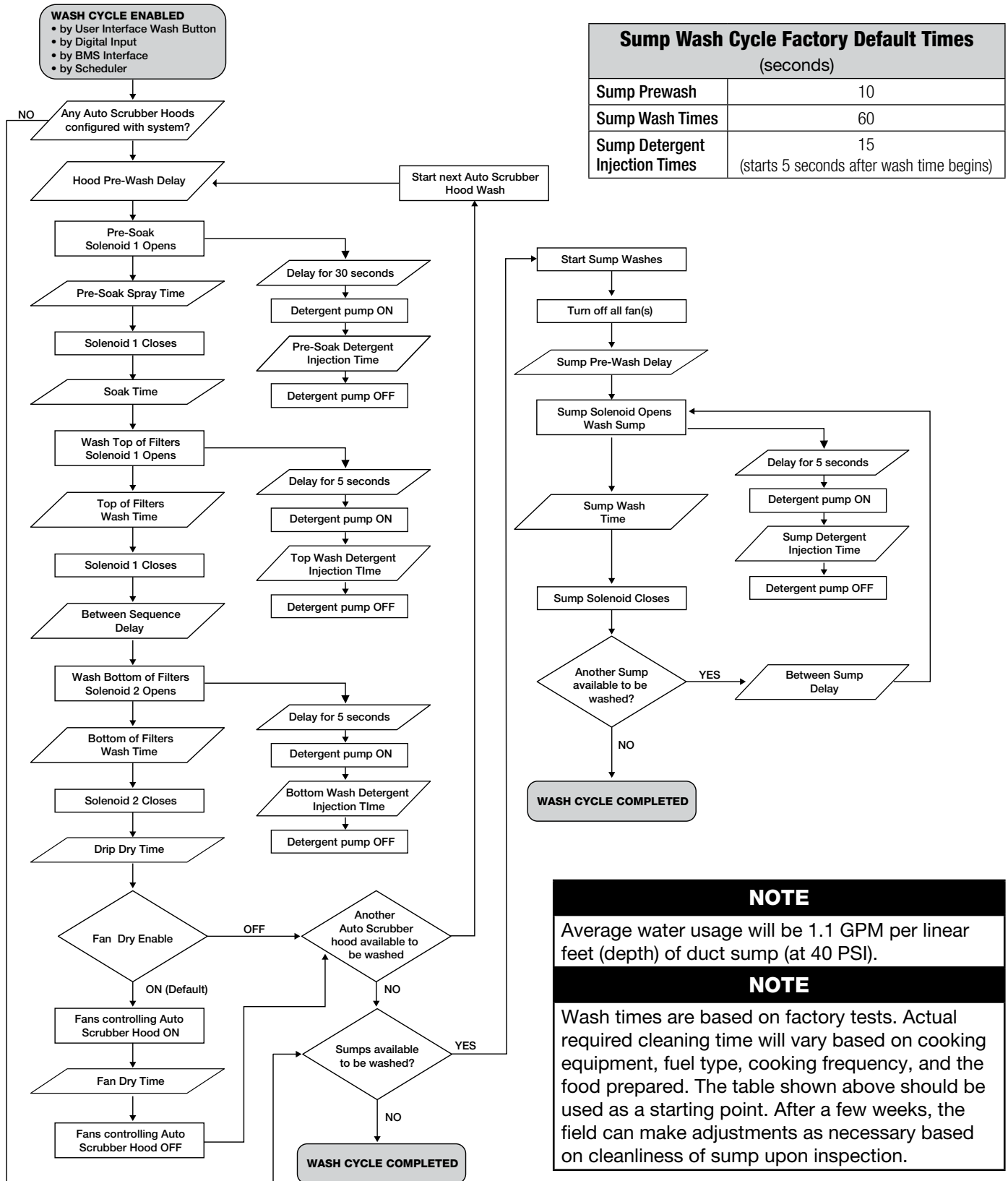

NOTE

Average water usage will be 1.1 GPM per linear feet (depth) of duct sump (at 40 PSI).

NOTE

Wash times are based on factory tests. Actual required cleaning time will vary based on cooking equipment, fuel type, cooking frequency, and the food prepared. The table shown above should be used as a starting point. After a few weeks, the field can make adjustments as necessary based on cleanliness of sump upon inspection.

Duct Sump Detail

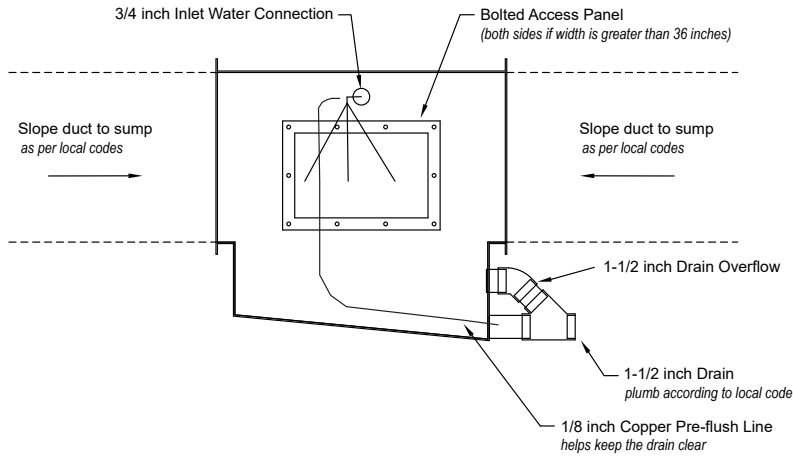

AVAILABLE SIZES:
 Width: 14 – 50 inches
 Height: 12 – 48 inches
 Length: 24 inches

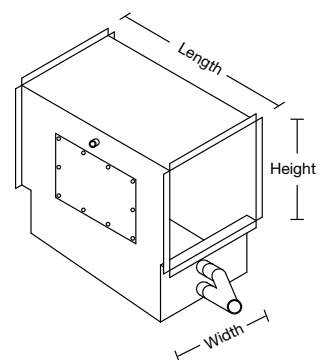

Typical Layout

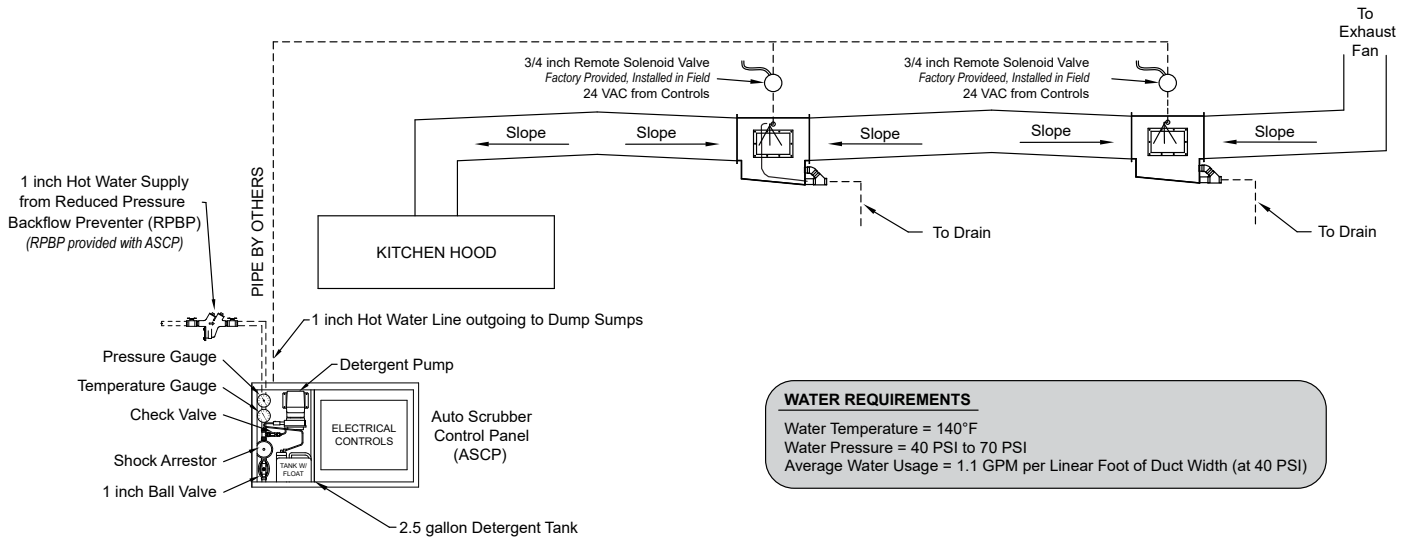

WATER REQUIREMENTS
 Water Temperature = 140°F
 Water Pressure = 40 PSI to 70 PSI
 Average Water Usage = 1.1 GPM per Linear Foot of Duct Width (at 40 PSI)

Maintenance

It is recommended that the duct sump(s) be washed daily using the ASCP control system on a schedule (during non-cooking operation). Detergent must be refilled when low detergent is detected.

Duct sumps opened up (via access doors) and washed manually with the rest of the ductwork as required when cleaning the entire exhaust system. Manually cleaning frequency shall be determined based on routine inspections and a determination by the AHJ.

NFPA 96 (2017) Table B.11.3 provides the following grease build-up inspection frequency table.

| Part Number | Description |
|-------------|--------------------------|
| 381050 | Duct Sump Solenoid Valve |
| 481463 | Duct Sump Solenoid Coil |

| Schedule of Inspection for Grease Buildup | |
|--|----------------------|
| Type of Volume of Cooking | Inspection Frequency |
| Systems serving solid fuel cooking operations | Monthly |
| *Systems serving high-volume cooking operations | Quarterly |
| Systems serving moderate-volume cooking operations | Semiannually |
| †Systems serving low-volume cooking operations | Annually |

*High-volume cooking operations include 24-hour cooking, charbroiling, and wok cooking.

†Low-volume cooking operations include churches, day camps, seasonal businesses, and senior centers.

Reproduced with permission from NFPA® 96-2017: *Standard for Ventilation Control and Fire Protection of Commercial Cooking Operations*, Copyright© 2016, National Fire Protection Association. This material is not the complete and official position of the NFPA on the referenced subject, which is represented only by the standard in its entirety which can be obtained through NFPA web site at www.nfpa.org

Maintenance Log

Date _____ Time _____ AM/PM

Notes: _____

Date _____ Time _____ AM/PM

Notes: _____

Date _____ Time _____ AM/PM

Notes: _____

Date _____ Time _____ AM/PM

Notes: _____

Date _____ Time _____ AM/PM

Notes: _____

Date _____ Time _____ AM/PM

Notes: _____

Date _____ Time _____ AM/PM

Notes: _____

Date _____ Time _____ AM/PM

Notes: _____

Date _____ Time _____ AM/PM

Notes: _____

Date _____ Time _____ AM/PM

Notes: _____

Date _____ Time _____ AM/PM

Notes: _____

Date _____ Time _____ AM/PM

Notes: _____

Date _____ Time _____ AM/PM

Notes: _____

Date _____ Time _____ AM/PM

Notes: _____



Maintenance Log

Date _____ Time _____ AM/PM
Notes: _____

Date _____ Time _____ AM/PM
Notes: _____

Date _____ Time _____ AM/PM
Notes: _____

Date _____ Time _____ AM/PM
Notes: _____

Date _____ Time _____ AM/PM
Notes: _____

Date _____ Time _____ AM/PM
Notes: _____

Date _____ Time _____ AM/PM
Notes: _____

Date _____ Time _____ AM/PM
Notes: _____

Date _____ Time _____ AM/PM
Notes: _____

Date _____ Time _____ AM/PM
Notes: _____

Date _____ Time _____ AM/PM
Notes: _____

Date _____ Time _____ AM/PM
Notes: _____

Date _____ Time _____ AM/PM
Notes: _____

Date _____ Time _____ AM/PM
Notes: _____



Our Commitment

As a result of our commitment to continuous improvement, Accurex reserves the right to change specifications without notice.

Specific Accurex product warranties are located on accurex.com within the product area tabs and in the Library under Warranties.



P.O. Box 410 Schofield, WI 54476
Phone: 800.333.1400 • Fax: 715.241.6191
Parts: 800.355.5354 • accurex.com