

BACnet Quick Start Guide

1 – Wire Network Connection

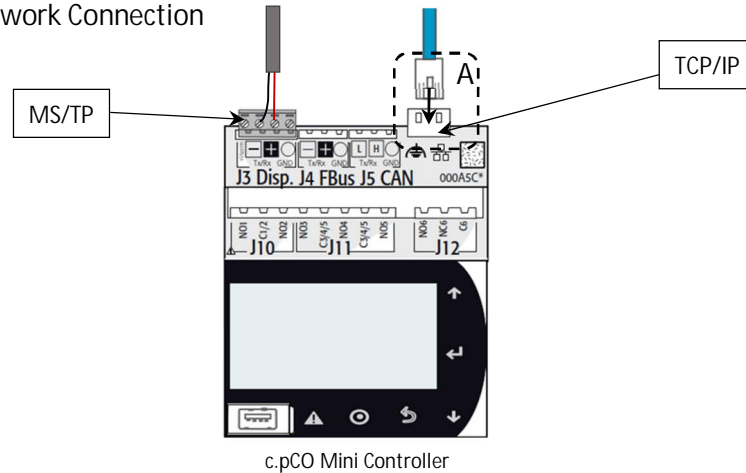

A – Ethernet Port Lights

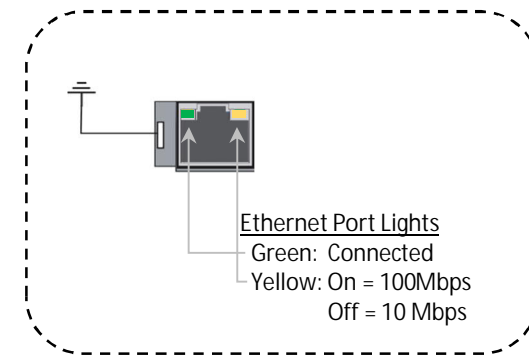

2 – Adjust BACnet Network Settings

Menu Structure Reference	
⊙	Main Menu
↓	Ctrl Variables
↓	Advanced
↓	Login
↓	Network Settings

2.1 – Enter User Password

```

User Login
Enter Password: 1000
-----
Current Access:
Read Only
    
```

2.2 – BACnet MS/TP Settings

```

BACnet MS/TP Config
Device:      0077077
Info Frames: 20
Max Masters: 127
Mstr Address: 77
Baud Rate:   9600
Save Settings: 
    
```

2.2 – BACnet IP Settings

```

PCU Board Address
Enable DHCP: 
IP:      192.168. 0.100
Mask:    255.255.255. 0
GW:      192.168. 0. 1
DNS:     192.168. 0. 1
Save Changes: 
    
```

```

BACnet IP Config
Device:      0077077
Port:        0047808
    
```

3 – Command Unit Operation

1. Enable Unit
2. Control Occupancy
3. Reset Alarms
4. Global Alarm Notification
5. Control Temperature Setpoint (optional)

Object	Object Name	Object Description	Active Text	Inactive Text
			Variable Type	
BV-2	System_Enable	Master system enable/disable point.	Enabled	Disabled
BV-3	BMS_Occupancy_Command	Occupancy Command	Unoccupied	Occupied
BV-4	Reset_All_Alarms	Alarm Reset Command	Reset	Normal
BV-19	Global_Alarm	Alarm Notification (any alarm by default)	Alarm	Normal
AV-1	Temperature_Setpoint	Sets the active temperature set-point based on mode of operation (space setpoint, return setpoint or supply setpoint). Not applicable for outside reset.	Default = 72°F Min = 50°F; Max = 100°F	

Reference Guide for BACnet Integration

Please read and save these instructions for future reference. The information in this guide assumes the controller was already configured with BACnet based on the original sales configuration. If the controller does not have BACnet enabled, please contact the equipment representative to get the necessary licensing and configuration files to allow BACnet communication to be used.

MUA_01.001 Rev 2
Document Date: 01/2023

Basic Unit Integration

Below are the basic integration functions available on all equipment regardless of control mode. Some features are unit configuration dependent (heating type, cooling type, etc.). The controller's BMS points list is static regardless of configuration to accommodate field configuration changes, however, not all points are applicable every unit. Once the required sensors are installed in the equipment, the only mandatory requirements to make the unit operational are to enable the unit, if it hasn't been enabled manually at the controller, and to command occupancy as desired.

Object	Variable	Description	Active Text	Inactive Text
Unit Enable/Disable Operation				
If desired, the unit can be enabled and disabled by the BMS system. In disabled mode, certain safety sequences may operate to protect the building and/or equipment but general heating, cooling and ventilation operation will not function.				
BV-2	System_Enable	Master system enable/disable command	Enabled	Disabled
Unit Occupancy Control				
By default, the unit occupancy is expected to be commanded by the BMS occupancy point. Alternatively, the unit occupancy can be controlled by an internal schedule, set to always unoccupied, always occupied or controlled by a digital input by changing the occupancy mode selection at the controller. If the controller is configured for warm-up/cool-down mode, after the occupancy command is received the unit will run in unoccupied recirculation mode until reaching the occupied temperature setpoint or the warm-up/cool down time expires (default 30 minutes) at which point the controller will enter normal occupied mode operation.				
BV-3	BMS_Occupancy_Command	Building Occupancy Command	Unoccupied	Occupied
Alarms				
The following points allow the notification of any alarm and the last alarm triggered to be read, as well as active alarms that to be manually reset remotely. See the unit's full BMS points list if specific alarm monitoring or trending is desired.				
BV-4	Reset_All_Alarms	Alarm Reset Command	Reset	Normal
BV-19	Global_Alarm	Global Alarm	Alarm	Normal
IV-9	LatestAlm	Most recent active alarm	See Alarm Table (0 = No Active Alarm)	
Monitoring Unit Operation				
Unit status				
AV-41	Unit_Status_Mode	Unit Operation Mode/State	See Status Mode Table	
Fans and Dampers				
BI-1	Exhaust_Fan_1_Status_Digital_Input	Exhaust Fan 1 Status	Active	Inactive
BI-2	Supply_Fan_1_Status_Digital_Input	Supply Fan 1 Status	Active	Inactive
AV-62	Outside_Airflow_Mask	Percentage of Outside Airflow	Real (%)	
AV-63	Supply_Fan_Speed_Analog_Output	Supply Fan Speed Analog Output	Real (%)	
Cooling				
IV-15* (Bit 20)	Cooling_is_On	Indicates that the unit is cooling	Active	Inactive
AV-43	Cooling_1_Ramp_Capacity	Cooling Ramp 1 Status Value	Real (%)	
Heating				
IV-15* (Bit 21)	Heating_is_On	Indicates that the unit is heating	Active	Inactive
AV-46	Heating_Capacity	Heating Ramp	Real (%)	
Filters				
IV-13* (Bit 3)	Filter_Alarm_Digital_Input	Filter Alarm Digital Input Status	Alarm	Normal
Refrigeration Systems				
IV-10* (Bit 3)	Compressor_1_Enable_Digital_Output	Compressor 1 Enable Digital Output	Active	Inactive
IV-10* (Bit 4)	Compressor_2_Enable_Digital_Output	Compressor 2 Enable Digital Output	Active	Inactive
AV-64	Modulating_Compressor_Analog_Output_BMS	Modulating Compressor Analog Output	Real (%)	

Object	Variable	Description	Active Text	Inactive Text
Chilled Water Systems				
AV-58	Chilled_Water_1_Valve_Analog_Output	Chilled Water 1 Valve Analog Output	Real (%)	
Evaporative Cooling Systems				
IV-10* (Bit 16)	Evap_Valve_Enable_Digit_Output	Evaporative Cooling Valve Enable	Active	Inactive
IV-10* (Bit 17)	Evap_Pump_Enable_Digit_Output	Evaporative Cooling Pump Enable	Active	Inactive
Hot Water Systems				
AV-60	Hot_Water_Valve_1_Analog_Output	Hot Water Valve 1 Analog Output	Real (%)	
IG Furnaces				
IV-10* (Bit 7)	Furnace_1_Stage_1_Digital_Output	Furnace 1 Stage 1 Digital Output	Active	Inactive
IV-10* (Bit 8)	Furnace_1_Stage_2_Digital_Output	Furnace 1 Stage 2 Digital Output	Active	Inactive
IV-10* (Bit 9)	Furnace_2_Stage_1_Digital_Output	Furnace 2 Stage 1 Digital Output	Active	Inactive
IV-10* (Bit 10)	Furnace_2_Stage_2_Digital_Output	Furnace 2 Stage 2 Digital Output	Active	Inactive
IV-10* (Bit 11)	Furnace_3_Stage_1_Digital_Output	Furnace 3 Stage 1 Digital Output	Active	Inactive
AV-61	Mod_Gas_Furnace_1_Analog_Output	Mod Gas Furnace 1 Analog Output	Real (%)	
Electric Post-Heat				
IV-10* (Bit 15)	Electric_Heater_Start_Stop_Digital_Output	Electric Heater Digital Output		
AV-59	Electric_Heater_1_Analog_Output	Electric Heater 1 Analog Output	Real (%)	
Direct Gas Burner				
IV-10* (Bit 14)	Direct_Gas_Heating_Enable_Digital_Output	Direct Gas Enable Digital Output	Active	Inactive
Sensor Values (when equipped)				
AI-1	Space_Temp_Analog_Input	Space Air Temperature	Real (°F)	
AI-2	Supply_Temp_Analog_Input	Supply(discharge) Air Temperature	Real (°F)	
AI-3	Outside_Air_Temp_Analog_Input	Outside Air Temperature	Real (°F)	
AI-9	Space_Static_Pressure_Analog_Input	Space Static Pressure	Real ("wc)	
AI-10	Supply_Duct_Static_Pressure_Analog_Input	Supply Duct Static Pressure	Real ("wc)	
AI-11	Space_CO2_1_Analog_Input	Space 1 CO2 ppm	Real (ppm)	
AI-12	Return_CO2_Analog_Input	Return CO2 ppm	Real (ppm)	
AV-56	OAD_CFM_BMS	Outdoor Air Damper CFM	Real (cfm)	
Active Setpoints				
AV-42	Supply_Temperature_Calculated_Setpoint	Active Supply Temperature Setpoint	Real (°F)	

* Please see [Binary Tables](#).

Unpacking Integer Words to Binary Values

Binary values can be combined to create an integer word. By doing this, more information is available to the BMS in a smaller number of points and less network traffic. These integer words need to be "unpacked" once the BMS receives the value.

Object	Variable	Description	Reference Table
Packed Integer Words			
IV-10	Digital_Output_Word	Digital Output Enables	Bit Packed Word - See Binary Tables
IV-11	Cooling_Alarm_Word	Cooling Device Alarms	Bit Packed Word - See Binary Tables
IV-12	Device_Offline_Word	Device Communication Alarms	Bit Packed Word - See Binary Tables
IV-13	Device_Alarm_Word	Device Alarms	Bit Packed Word - See Binary Tables
IV-14	Heating_Alarm_Word	Heating Device Alarms	Bit Packed Word - See Binary Tables
IV-15	Unit_Status_Word	Unit Status Word	Bit Packed Word - See Binary Tables

To unpack the integer word into the binary values, the integer needs to be converted to a binary number. The integers in the program are 32-bit, meaning up to 32 binary values are packed into the integer. Each bit can either be a 0 (Inactive) or a 1 (Active).

The BMS front end may have a solution already intact to pull individual bits from an integer. A "read bit" function looks to return what value a certain bit is in an integer. Bit numbers are 0-31 in a 32-bit integer with 0 being the lowest bit and the furthest to the right in the binary notation of the number. Bit 31 would be the largest bit and the furthest to the left in binary notation.

If the front end does not have a "read bit" or "bit extract" function, the binary value of individual bits can be determined by continually dividing the quotient of the integer by 2, the remainder of the division is the value of the bit (0 or 1). A function called Modulo or "mod" and is commonly used to return the remainder of integer division.

Equation: $x = (\text{round down}(a/2^b)) \bmod 2$

- x is Boolean value for bit b, where 0 is inactive and 1 is active.
- a is the integer word value
- b is the bit of the binary number used as an exponent
- The result of $a/2^b$ should round down to a whole number, truncating the decimal. For example, $5/2^1$ is 2.5, however, only the 2 is used.

Example:

If the Device_Offline_Word (IV-12) is a decimal value of 11, the binary value would be 1011. This binary value would mean that Space Thermostats 1, 2, and 4 are offline. The rest of the bits in the binary number would be a Boolean value of 0. (Please see [Binary Tables](#).)

- Bit 0 = $11/2^0 \bmod 2$... this results in a Boolean of 1 or Active for bit 0.
- Bit 1 = $11/2^1 \bmod 2$... this results in a Boolean of 1 or Active for bit 1.
- Bit 2 = $11/2^2 \bmod 2$... this results in a Boolean of 0 or Inactive for bit 2.
- Bit 3 = $11/2^3 \bmod 2$... this results in a Boolean of 1 or Active for bit 3.

Bit	31	30	29	28	27	26	25	24	23	22	21	20	19	18	17	16	15	14	13	12	11	10	9	8	7	6	5	4	3	2	1	0
Val	0	0	0	0	0	0	0	0	0	0	0	0	0	0	0	0	0	0	0	0	0	0	0	0	0	0	0	0	1	0	1	1

Modifying Equipment Operation

In addition to commanding unit occupancy, some system level sequences may require feedback from the BMS. Common BMS adjusted sequences include items like supply air temperature reset control, demand control ventilation for multiple zones, and duct static pressure reset.

HEATING AND COOLING OPERATION SETPOINTS

Object	Variable	Description	Active Text	Inactive Text
Adjusting Temperature Setpoints				
Controller Provided Sequences – Occupied Mode				
The controller has several stand-alone supply air temperature control modes with setpoints that can be modified by the BMS. These modes include a static supply air temperature setpoint (no-reset) or allows for the supply air temperature setpoint to be reset based on outside air temperature, space temperature, or return air temperature.				
IV-1	Temperature_Reset_Mode	Commands the reset mode during occupied operation.	1 = No Reset, 2 = Space Reset 3 = Return Reset, 4 = Outside Reset	
AV-1	Temperature_Setpoint	Sets the temperature setpoint based on mode of operation (space setpoint, return setpoint or supply setpoint). Not applicable for outside reset.	Real, Default = 72°F *Min = 50°F; Max = 120°F	
AV-2	Temperature_Heat_Cool_Deadband	Heat/Cool Setpt Deadband when Space or Return reset control is active. Htg Setpt = Temp Setpt - Deadband /2 Clg Setpt = Temp Setpt - Deadband /2	Real, Default = 4°F Min = 0.1°F; Max = 20°F [Space/Return Heating = 70°F, Space/Return Cooling = 74°F]	
Controller Provided Sequences – Unoccupied Mode				
When the unoccupied mode of operation is set to night setback temperature, normal operation with unoccupied setpoints, or recirculation with unoccupied setpoints, the following setpoints control unoccupied heating and cooling operation. If night setback is selected as the Unoccupied Mode of operation, the reset mode will not be available to change at the controller and should be set to Space Reset(2).				
IV-2	Temperature_Reset_Mode_Unoccupied	Commands the reset mode during occupied operation.	1 = No Reset, 2 = Space Reset 3 = Return Reset, 4 = Outside Reset	
AV-3	Temperature_Setpoint_Unoccupied	Sets the temperature setpoint based on mode of operation (space setpoint, return setpoint or supply setpoint). Not applicable for outside reset.	Real, Default = 72.5°F *Min = 50°F; Max = 120°F	

* Typical range for standard configuration unit, please verify at point min and max properties.

Object	Variable	Description	Active Text	Inactive Text
AV-4	Temperature_Heat_Cool_Deadband_Unoccupied	Heat/Cool Setpt Deadband when Space or Return reset control is active. Unoc Clg Setpt = Deadband /2 + Temp Setpt Unocc Htg Setpt = Deadband /2 - Temp Setpt	Real, Default = 15°F Min = 0.1°F; Max = 40°F [Space/Return Heating = 65°F, Space/Return Cooling = 80°F]	
BMS Controlled Sequences				
BMS control over reset write to temp setpoint and have mode in No reset.				

AIRFLOW OPERATION SETPOINTS

Object	Variable	Description	Active Text	Inactive Text
Airflow Setpoints				
Airflow operation of supply fan, exhaust fan, and mixing dampers may use setpoints from duct pressure, space pressure, CO2 sensors, or airflow measuring stations to properly control airflow in an application. The Outside Air Damper Minimum Setpoint Occupied applies to all units with modulating outside air dampers. The setpoint is used to establish an absolute minimum position for ventilating the space while allowing other control modes to open the damper further as necessary. Outdoor and recirculating air dampers operate inversely using the same signal.				
AV-16	Space_Static_Pressure_Setpoint	Space Static Pressure Setpoint	Default = 0.05"wc Min = -0.5"wc; Max = 0.5"wc	
AV-17	Supply_Duct_Static_Pressure_Setpoint	Supply Duct Static Pressure Setpoint	Default = 1.0"wc Min = 0"wc; Max = 5"wc	
AV-18	Space_CO2_Setpoint	Space CO2 Setpoint	Default = 1,000 ppm Min = 0 ppm; Max = 5,000 ppm	
AV-19	Outside_Air_Damper_Minimum_Setpoint_Occ	Outside Air Damper Minimum Setpoint Occupied	Default = 35% Min = 0%; Max = 100%	

BMS Watchdog Enabled Control

BMS WATCHDOG

When directly commanding fans speeds, damper positions, or sending sensor values, the unit controller requires the BMS Watchdog point to be written to on a recurring basis. This tells the unit controller that the BMS is still actively communicating.

Object	Variable	Description	Active Text	Inactive Text
BMS Watchdog				
The BMS Watchdog must be written to True (1) regularly to verify communication is established between the unit controller and the BMS headend system. If the BMS Watchdog value remains False(0) for longer than the Timeout Delay (15 minutes, adjustable), an alarm is generated and the controller falls back to local control and sensor values, as applicable, instead of using BMS commanded values.				
BV-1	BMS_Watchdog	BMS Watchdog command	Active	Inactive
BV-20	BMS_Watchdog_Active	Status of the BMS watchdog ping.	Active	Inactive

CONTROLLING AIRFLOW DEVICES

If desired, the speeds and positions of airflow devices can be controlled directly using BACnet commandable points. To control the devices via the BMS, the BMS Watchdog requirements must be satisfied.

Object	Variable	Description	Active Text	Inactive Text
Fan Controls				
Fan speeds can be controlled directly through BMS points. The binary points enable the BMS to take control and the analog values command the speeds as a percentage between the allowed minimum and maximum values set in the controller.				
Supply Fan				
BV-14	SF_Control_Source_BMS	Allows the BMS to control supply fan speed	BMS	Local
AV-38	SF_Control_Signal_BMS	Supply Fan Command Speed	Real (%) *Min=50%; Max=100%	
Outdoor Air/Recirculation Air Damper Control				
The outdoor air damper position can be controlled directly by the BMS to adjust the mixture of outdoor air and recirculation air on units configured for recirculation. Minimum and maximum values for occupied and unoccupied mode set at the unit controller are enforced.				
BV-15	OAD_Control_Source_BMS	Allows the BMS to control OAD position	BMS	Local
AV-39	OAD_Control_Signal_BMS	Outside Air Damper Control Signal via BMS	Real (%) Min=0%; Max=100%	

* Typical range for standard configuration unit, please verify at point min and max properties.

SENDING SENSOR VALUES

Sensor values required for sequence operation can be sent to the controller over dedicated BMS points in place of a sensor wired to the controller (local sensor). When values are communicated to the controller over BMS, the BMS Watchdog must be satisfied. If the watchdog isn't satisfied, the controller reverts to the local sensor (if installed and valid) to control the unit or falls back to local control until the BMS watchdog is satisfied.

Object	Variable	Description	Active Text	Inactive Text
BMS Writeable Sensor Values				
To write the sensor values over BMS, first command the controller to use the BMS value using the corresponding binary value and then use the corresponding analog value to send the sensor value.				
Sensor Sources				
BV-6	Outside_Temp_Source_BMS	Outside Temp Source Selection	BMS	Local
BV-9	Space_1_CO2_Source_BMS	Space 1 CO2 Source Selection	BMS	Local
BV-10	Return_CO2_Source_BMS	Return CO2 Source Selection	BMS	Local
BV-12	Space_Static_Source_BMS	Space Static Source Selection	BMS	Local
BV-13	Space_Temp_Source_BMS	Space Temp Source Selection	BMS	Local
Sensor Values				
AV-30	Outside_Temp_from_BMS	Outside Temp from BMS		Real (°F)
AV-33	Space_1_CO2_from_BMS	Space 1 CO2 from BMS		Real (ppm)
AV-34	Return_CO2_from_BMS	Return CO2 from BMS		Real (ppm)
AV-36	Space_Static_from_BMS	Space Static from BMS		Real ("wc)
AV-37	Space_Temp_from_BMS	Space Temp from BMS		Real (°F)

Advanced BACnet Settings

Menu Structure Reference	
⊙	Main Menu
↓	Control Variables
↓	Advanced
↓	Network Settings
↓	Advanced Settings

Additional settings can be accessed in the BACnet Advanced Settings menu including BACnet Broadcast Management Device (BBMD) configuration, relinquish default settings, Change of Value (COV) increments and restoring binary text values.

BBMD CONFIGURATION

BACnet IP Config	
▲	Foreign Device Config
○	Access: Read
	BBMD: 000.000.000.000
	Time to Live: 60
↶	

To configure the controller to operate with a BACnet Broadcast Management Device (BBMD) on IP networks, go to the advanced BACnet settings menu and enter the IP address of the BBMD, foreign device configuration, and time to live settings.

COV INCREMENTS

BACnet COV Increment	
▲	PPM: 10PPM
	Pressure: 5.0Psi
○	Static: 0.001"wc
	Temp: 0.1F
	Airflow: 100 cfm
	Enthalpy: 0.5btu/lb
↶	Percent: 1.0%

BACnet COV is an optional portion of BACnet that supports providing new values/information only after an increase or decrease of the value is at least the listed COV increment. The controller's COV increments are based on the unit of measure. All variables with the same unit of measure share the same COV increment value. Values can be adjusted on this screen, or by writing to the COV increment property of any BACnet object.

RELINQUISH DEFAULT SETTINGS

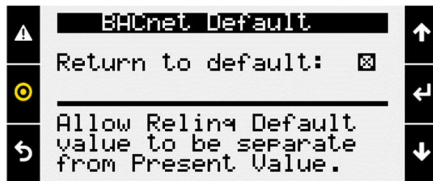

When the Return to Default function is enabled, the present value will not overwrite the relinquish default value and on a loss of power the controller will boot with last saved default values instead of last written values. This must also be enabled for the BACnet Comm Loss relinquish default to work.

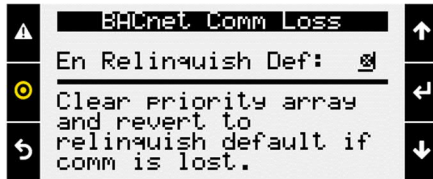

When the Enable Relinquish Default function is enabled any value in the priority array for binary values or analog values will be cleared if a communication loss is detected. All commandable points will revert to the relinquish default value.

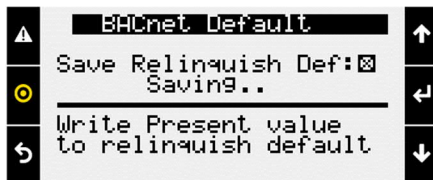

Communication loss is determined based on the BMS Watchdog. The watchdog function must be enabled. The function will execute 5 minutes after the watchdog status goes inactive.

This may be desired if the BMS is running a reset routine on the setpoints and would like to revert to a default state if communication is lost. It is recommended to be used with return to default enabled, and a known relinquish default is saved.

When this box is checked by a user, the controller will write the present value of variables to the relinquish default for all binary and analog value BACnet objects that are commandable. The function operates in the background and takes approximately 30 seconds to complete.

This is desired to save any Test and Balance settings adjusted locally on the controller to be the BACnet relinquish default values. Alternatively, these values could be read and written to the relinquish default variables by the BMS system.

BINARY TEXT

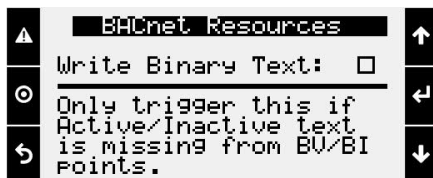

If for any reason, the state text is missing from binary objects, checking this box will cause the controller to re-write the active and inactive text values.

MUA Reference Tables

STATUS MODE TABLE

The following analog values can appear in the point to tell the building automation the current mode of operation of the unit. Values may rotate every three seconds.

Status Mode Table (AV-41)					
Analog Value	Mode	Analog Value	Mode	Analog Value	Mode
0	Off/Standby	10	System On	21	Cooling
1	Unoccupied Start	11	Soft Shutdown	22	Heating
2	Occupied Start	12	System Disabled	30	Overrides
3	Opening Dampers	13	Remote Off	31	Expansion Offline
5	Dampers Open	14	System Shutdown Alarm	32	Occupancy Overridden
6	Fan Start Delay	18	Unit Off Flow Active	33	Max Vent Sequence Active
7	Exhaust Fan Start	19	Fans Only	35	Morning Sequence Active
8	Supply Fan Start	20	Economizing	36	Winter Ramp Active
9	Startup Delay				

ALARM TABLE

This table displays the latest alarm that is active in the unit controller.

Alarm Table - Latest Alarm (IV-9)					
0	No Active Alarms	27	IG Furnace 1 Combust Fan High Pressure Switch		
1	Supply Fan Run Status Not Proven	28	IG Furnace 1 Ignition Controller Alarm		
2	Exhaust Fan Run Status Not Proven	29	IG Furnace 1 Pressure Switch Fault Alarm		
3	Filters are Dirty Replace Filters	30	IG Furnace 1 Combust Fan Proving Alarm		
4	Cond Drain Pan Full Check Drain	31	IG Furnace 1 Max Retries		
5	High Supply Duct Static Pressure	32	IG Furnace 1 High Limit Trip		
6	Outside Air Temp Sensor Value Not Valid	33	IG Furnace pCOe 1 Offline		
7	Space Temperature Sensor Value Not Valid	34	IG Furnace 1 IC Fault Check IC->pCOe Wiring		
8	Supply Air Temperature Sensor Value Not Valid	35	IG Furnace 1 Combustion Fan Alarm		
9	Outside Air GreenTrol Offline or Flow Error	36	IG Furnace pCOe 2 Offline		
10	Hi/Low Pressure Switch Circuit A	37	IG Furnace 2-No Flame Alarm After 3 Tries		
11	Hi/Low Pressure Switch Circuit B	38	IG Furnace 2 Max Retries		
12	Space CO2 Sensor Value Not Valid	39	IG Furnace 2 Ignition Controller Alarm		
13	Return CO2 Sensor Value Not Valid	40	IG Furnace 3-No Flame Alarm After 3 Tries		
14	Space Static Pressure Sensor Value Not Valid	41	IG Furnace 3 Max Retries		
15	Supply Duct Stat Press Sensor Value Not Valid	42	IG Furnace 3 Ignition Controller Alarm		
16	Supply Air Temperature Low Limit Shutdown	43	DG Flame Safeguard General Reference		
17	Supply Air Temperature High Limit Shutdown	44	DG Flame Safeguard Manual Reset at FSG		
18	Space High Static Pres Shutdown	45	DG Pilot Flame Alarm Did Not Prove		
19	BMS Offline Watchdog is FALSE	46	DG Heating Safety Check Circuit		
20	BACnet License Not Installed	47	DG Flame Safeguard Check Functionality		
21	Space Thermostat 1 Sensor Offline	48	DG Burner Differential Check Pressure		
22	Space Thermostat 2 Sensor Offline	51	Multi Devices per Ch Contact Tech Support		
23	Space Thermostat 3 Sensor Offline	52	Comp Maintenance Alarm Run Hours Setpoint Reached		
24	Space Thermostat 4 Sensor Offline	54	Non-Volatile Memory Er Contact Tech Support		
25	IG Furnace 1-No Flame Alarm After 3 Tries	55	Cooling Exp Board pCOe 3 Offline		
26	IG Furnace 1 - Large No Flame After 3 Tries	59	Exp Board 4 Status Board is Offline		

BIT-PACKED INTEGER WORD TABLES

The following tables are used to unpack integer words into Boolean values.

Digital Output Table (IV-10)					
Bit	Digital_Output_Word	Bit	Digital_Output_Word	Bit	Digital_Output_Word
0	Supply Fan Start	11	Furnace 3 Start	22	
1	Exhaust Fan Start	12		23	
2	Exhaust Relief Enable	13	Damper Actuator Power Enable	24	
3	Compressor 1 Start	14	Direct Gas Start	25	
4	Compressor 2 Start	15	Electric Heat Start	26	
5	Condenser Fan Start	16	Evaporative Cooling Valve Enable	27	
6		17	Evaporative Cooling Pump Enable	28	
7	Furnace 1 Start	18		29	
8	Furnace 1 Stage 2 Start	19		30	
9	Furnace 2 Start	20		31	
10	Furnace 2 Stage 2 Start	21			

Cooling Alarm Table (IV-11)					
Bit	Cooling_Alarm_Word	Bit	Cooling_Alarm_Word	Bit	Cooling_Alarm_Word
0	Circuit A High/Low Pressure Switch Alarm	11		22	
1	Circuit B High/Low Pressure Switch Alarm	12		23	
2		13		24	
3		14		25	
4		15		26	
5		16		27	
6		17		28	
7		18		29	
8		19		30	
9		20		31	
10		21			

Device Offline Table (IV-12)					
Bit	Device_Offline_Word	Bit	Device_Offline_Word	Bit	Device_Offline_Word
0	Space T-Stat 1 Offline	11		22	
1	Space T-Stat 2 Offline	12		23	
2	Space T-Stat 3 Offline	13		24	
3	Space T-Stat 4 Offline	14		25	
4	IG Furnace Controller 1 Offline	15		26	
5	IG Furnace Controller 2 Offline	16		27	
6	Cooling Controller Offline	17		28	
7	GreenTrol Outside Air Offline	18		29	
8	BMS Offline Alarm	19		30	
9	Permanent Memory - Too Many Writes	20		31	
10		21			

Device Alarms Table (IV-13)					
Bit	Device_Alarm_Word	Bit	Device_Alarm_Word	Bit	Device_Alarm_Word
0	Supply Fan Alarm	11	Supply High Duct Static Alarm	22	
1	Exhaust Fan Alarm	12	Supply Duct Static Sensor Alarm	23	
2	Drain Pan Alarm	13	Space Static Pressure Sensor Alarm	24	
3	Filter Alarm	14	Space High Static Alarm	25	
4	GreenTrol OAD AFMS Alarm	15	Return CO2 Sensor Alarm	26	
5	Outside Air Temp Sensor Alarm	16		27	
6	Space CO2 Sensor Alarm	17	Shutdown Input Alarm	28	
7	Supply Air Temp Sensor Alarm	18		29	
8	Space Temperature Sensor Alarm	19		30	
9	Supply Temp Low Limit Alarm	20		31	
10	Supply Temp High Limit Alarm	21			

Heating Alarm Table (IV-14)					
Bit	Heating_Alarm_Word	Bit	Heating_Alarm_Word	Bit	Heating_Alarm_Word
0	DG Flame Safeguard General Reference	11	IG Furnace 1 Pressure Switch Fault Alarm	22	IG Furnace 3 Ignition Controller Alarm
1	DG Flame Safeguard Manual Reset at FSG	12	IG Furnace 1 Combust Fan Proving Alarm	23	
2	DG Pilot Flame Alarm Did Not Prove	13	IG Furnace 1 Max Retries	24	
3	DG Heating Safety Check Circuit	14	IG Furnace 1 High Limit Trip	25	
4	DG Flame Safeguard Check Functionality	15	IG Furnace 1 IC fault Check Furnace Wiring	26	
5	DG Burner Differential Check Pressure	16	IG Furnace 1 Combustion Fan Alarm	27	
6	General IG Furnace Alarm	17	IG Furnace 2-No Flame Alarm After 3 Tries	28	
7	IG Furnace 1 No flame Alarm After 3 Tries	18	IG Furnace 2 Max Retries	29	
8	IG Furnace 1 Large No Flame After 3 Tries	19	IG Furnace 2 Ignition Controller Alarm	30	
9	IG Furnace 1 Combust Fan High Pressure Switch	20	IG Furnace 3-No Flame Alarm After 3 Tries	31	
10	IG Furnace 1 Ignition Controller Alarm	21	IG Furnace 3 Max Retries		

Unit Status Word Table (IV-11)					
Bit	Unit_Status_Word	Bit	Unit_Status_Word	Bit	Unit_Status_Word
0	Off/Standby	11	Remote Off	22	Dehumidifying
1	Unoccupied Start	12	System Shutdown Alarm	23	Hot Gas Reheat Active
2	Occupied Start	13	Supply Fan Only	24	HGRH Purging
3	Opening Dampers	14	Exhaust Fan Only	25	Dehum w/Heat
4	Dampers Open	15	Purge Mode (Supply and Exhaust Only)	26	Energy Recovery Defrost Active
5	Fan Start Delay	16	Case Heat Active	27	Heat Pump Defrost Active
6	Exhaust Fan On	17	Fans Only	28	Morning Warm Up/Cool Down Active
7	Supply Fan On	18	Economizing	29	Winter Ramp Active
8	System On	19	Energy Recovery Active	30	
9	Soft Shutdown	20	Cooling	31	Overrides Active
10	System Disabled	21	Heating		

