

Installation, Operation and Maintenance Manual

Please read and save these instructions for future reference. Read carefully before attempting to assemble, install, operate or maintain the product described. Protect yourself and others by observing all safety information. Failure to comply with these instructions will result in voiding of the product warranty and may result in personal injury and/or property damage.

PRG VERSION: V3.00



UL Listed to Standard 891
PCBs - UL Certified to 60730-1 Standard
PCBs - UL Certified to CSA-E60730-1 Standard
Complies with IMC, NEC, CEC, and NFPA 96

General Safety Information

Only qualified personnel should install this system. Personnel should have a clear understanding of these instructions and should be aware of general safety precautions. Improper installation can result in electric shock, possible injury due to coming in contact with moving parts, as well as other potential hazards. If more information is needed, contact a licensed professional engineer before moving forward.

1. Follow all local electrical and safety codes, as well as the National Electrical Code (NEC) and the latest edition of the National Fire Protection Agency Standard for Ventilation Control Operations (NFPA 96). Follow the Canadian Electrical Code (CEC) and ULC-S650 if installing this product in Canada.
2. Do not allow the electrical components of this unit to come in contact with oil, grease, hot surfaces, water, or chemicals. Replace cord immediately if damaged.
3. Verify the site can supply the necessary power for each fan and for the control panel.

WARNING

Electrical shock hazard. Can cause equipment damage, personal injury or death. Service must only be performed by personal that are knowledgeable in the operation of the equipment being controlled.

DANGER

Always disconnect power before working on or near the product. Lock and tag the disconnect switch or breaker to prevent accidental power up.

CAUTION

When servicing the product, variable frequency drives may be hot enough to cause pain or injury. Allow motor to cool before servicing.

CAUTION

It is the responsibility of the installer to make sure both electrical and gas appliances shut down in the event of a fire or in the event of a power loss to the building when this sequence is required by the authority having jurisdiction.

Table of Contents

- General Safety Information 1
- Receiving and Handling 2
- Model Name 2
- Installation 3
- Electrical Connections 7
- Electrical Connection Checklist 17
- General Field Wiring Diagram 18
- User Interface (UI) Operation – End User 19
- Settings Navigation – Factory Authorized Servicer . . 21
- Sequence of Operation 33
- System Optimization 34
- Maintenance 35
- Troubleshooting 36
- Variable Frequency Drive (VFD) Information 38
- BACnet IP Network Information 39
- BMS Modbus (RTU) Points List 40
- BACnet Points List 43
- Main Board Connector Information 48
- Replacement Parts List 50
- Maintenance Log. 51

Receiving and Handling

Receiving

Upon receiving the product, check to make sure all items are accounted for by referencing the bill of lading to ensure all items were received. Notify the carrier if any damage is noticed. The carrier will make a notation on the delivery receipt acknowledging any damage to the product. All damage should be noted on all the copies of the bill of lading which is countersigned by the delivering carrier. If damaged upon arrival, file claim with the carrier. Any physical damage to the unit after acceptance is not the responsibility of manufacturer.

Unpacking

Verify that all required parts and the correct quantity of each item have been received. If any items are missing, report shortages to your local representative to arrange for obtaining missing parts.

Storage

Control panel must be stored prior to installation, it must be protected from dirt and moisture. Indoor storage is highly recommended.

NOTE

Improper storage which results in damage to the unit will void the warranty.

Handling

Make sure the equipment does not suffer any heavy vibration or knocks.

Model Name

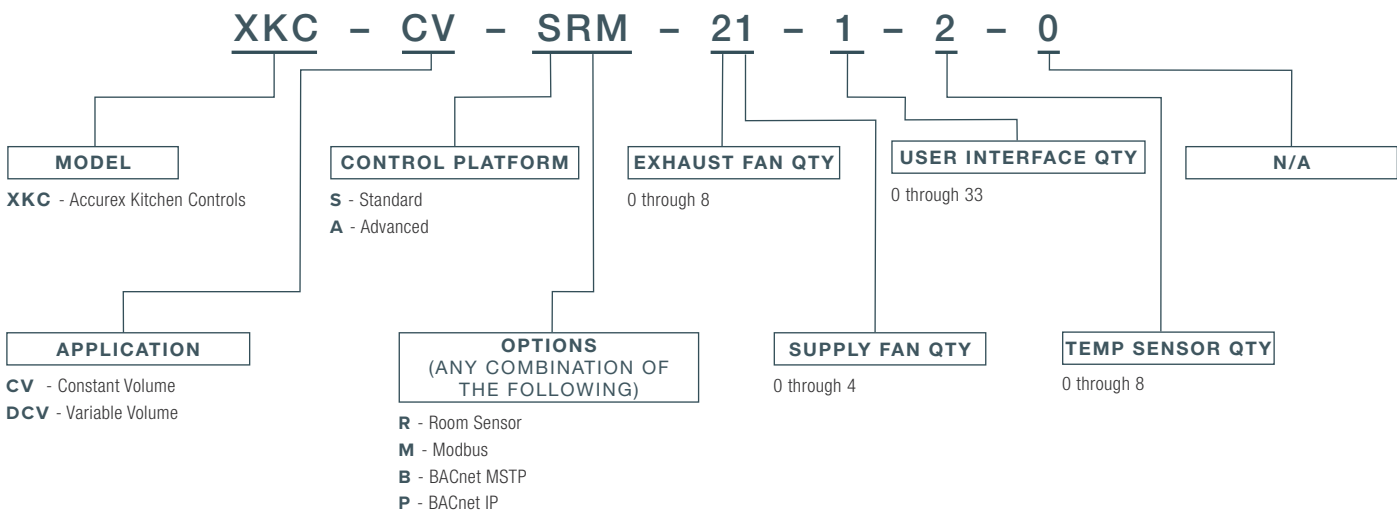

Installation

Enclosure Mounting

Locate an area with enough space to mount the control enclosure and fasten to wall. Enclosure size will be either 12", 18", or 25" long depending on what the panel was configured to control. If VFDs are mounted inside, the enclosure will be 9" deep. See below for dimension data.

NOTE

Enclosure may be factory mounted in a hood or wall utility cabinet. If so, continue to next section.

NOTE

Minimum of 36" clearance recommended in front of control enclosure.

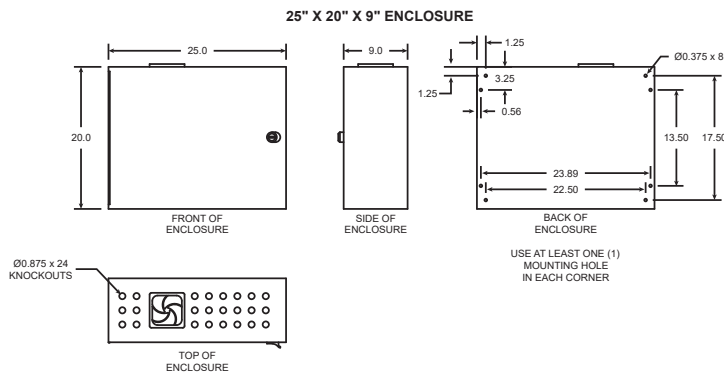
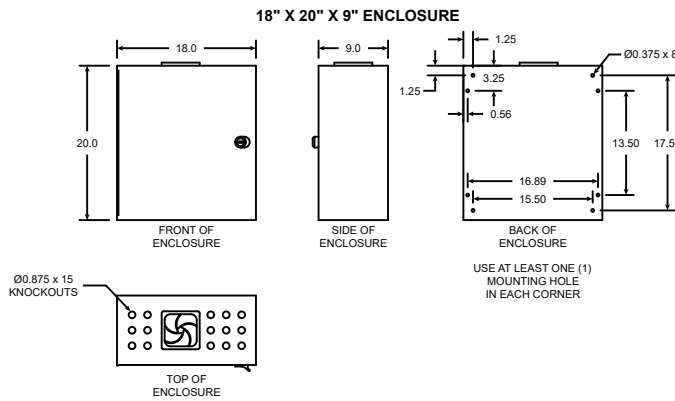
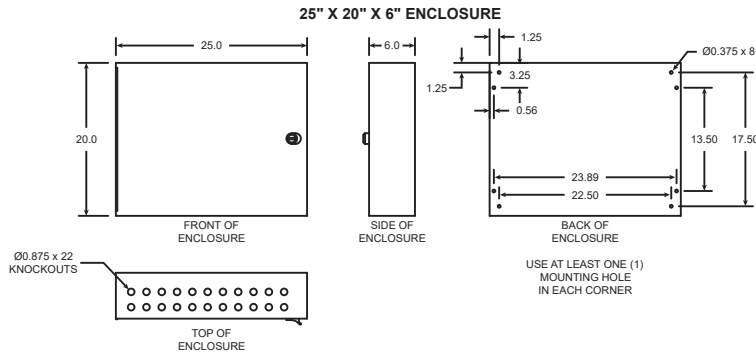
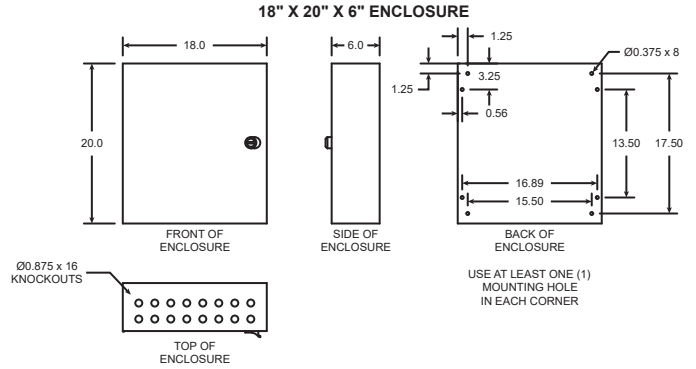
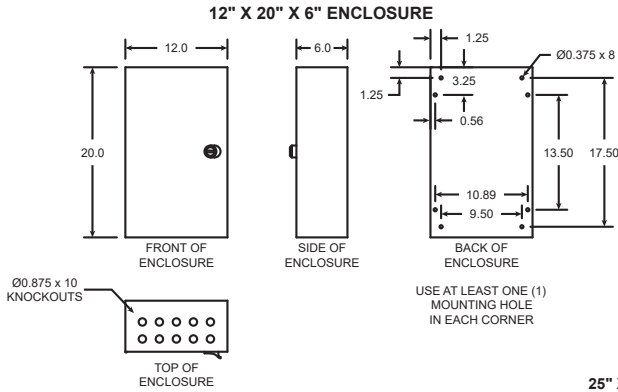

Utility Cabinet Mounting – If equipped

NOTE

Utility cabinet may be factory mounted to the side of a hood. If so, continue to next section.

NOTE

Minimum of 36" clearance recommended in front of control cabinet.

Locate an area with enough space to mount the utility cabinet and fasten to wall. Utility cabinet length will vary based on what the panel was configured to control.

Temperature Sensor(s) Mounting

1. Locate flat area(s) at the top interior of the hood in front of the filters, towards the front of the hood.

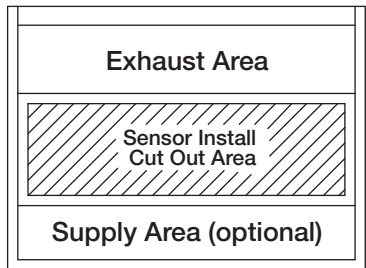

Top View of Exhaust Hood

NOTE

Temperature sensors can also be installed in exhaust collar, if the hood doesn't have enough room in the flat space in front of the filters.

2. Find a suitable location for the sensor in the flat space which will not interfere with the fire suppression nozzles and is not within 12 inches (304.8 mm) of any light fixtures. Cut a 3/4 to 7/8-inch (19.0 to 22.2 mm) diameter hole in the flat spot of the capture tank.

.75 to .875 inch
diameter hole

Hood
Surface

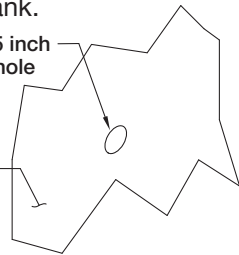

3. Center the octagon extension over the hole on the hood surface.

Octagon
Extension

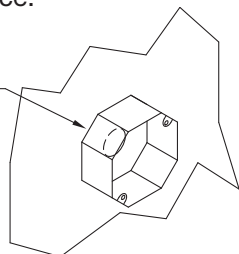

4. Insert the compression seal into the hole from the inside of the hood making sure the gasket is placed on the fitting before inserting it into the hole. Place the octagon box and J-box plate provided over the fitting on the top of the hood, keeping the fitting centered in the box. Install the lock washer and 1-1/2 inch (38.1 mm) nut on the threaded portion of the compression seal and tighten securely.
5. Insert the temperature sensor into compression seal and tighten to 35 ft-lbs (47.5 Nm).

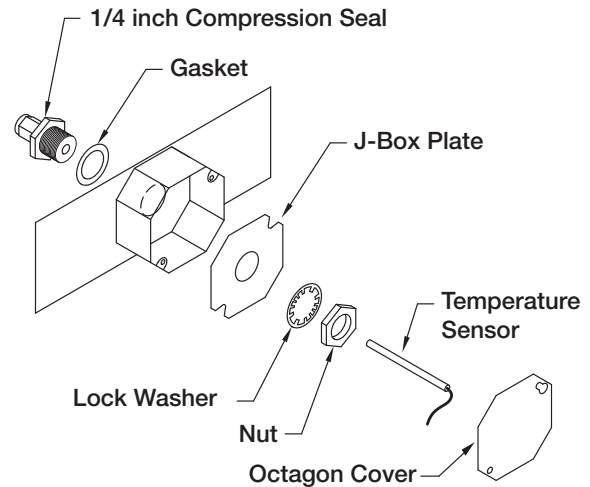

6. At this point, wire the temperature sensor back to the kitchen control panel. Follow wiring instructions found on page 12.
7. Place octagon cover onto J-box plate and fasten it.



User Interface Mounting

NOTE

The user interface may be factory mounted. If so, continue to the next section.

User interface (UI) is full color touchscreen mounted in 4x4 galvanized box. It connects back to the main control board using factory-provided CAT5 ethernet cable. User interface is intended to be recessed into a wall if shipped loose.

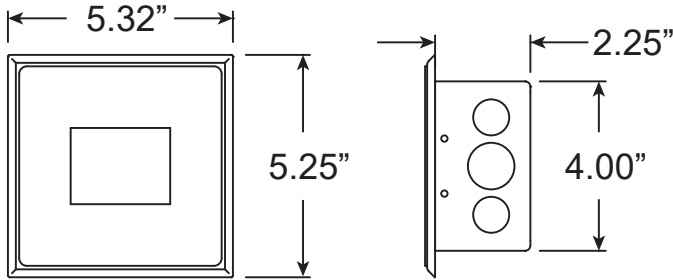

UI J-BOX PROVIDED WITH:

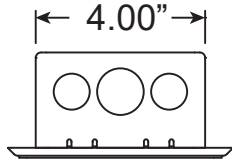

TWO (2) Ø0.875" AND ONE (1) Ø1.094" KO ON EACH SIDE.

THREE (3) Ø0.875" AND TWO (2) Ø1.094" KO ON BOTTOM.

To mount user interface:

1. Remove user interface cover by pulling up on cover plate (it should pop off j-box).
2. Fasten the j-box securely in wall so that the j-box opening is flush with the drywall/wall construction (fasteners by others). J-box offset plate should be resting on the wall.

1. CUT 4X4-INCH HOLE IN WALL FOR J-BOX

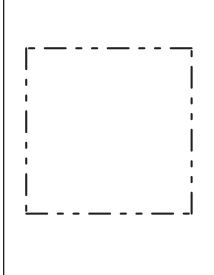

2. SECURE J-BOX INTO WALL USING FASTENERS (BY OTHERS)

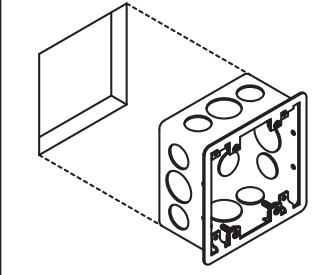

3. OFFSET PLATE SHOULD REST AGAINST WALL SURFACE

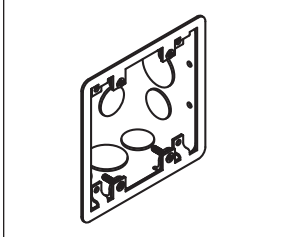

3. Route factory provided CAT5 ethernet cable from user interface box back to main control panel. Cable is plenum rated and does not need to be run through conduit unless required by local codes. See Electrical Connections section for information on where to connect the user interface back to the main control enclosure.

NOTE

If running UI cable through conduit, do not route in the same conduit as any 120V or high voltage cable.

4. Connect cable on the only RJ45 ethernet port on the back of the user interface (labeled "MB-UI (TO MB J15)").
5. Snap cover plate back onto the j-box by lining up the standoffs with the holes on the j-box offset plate. Press firmly to attach.

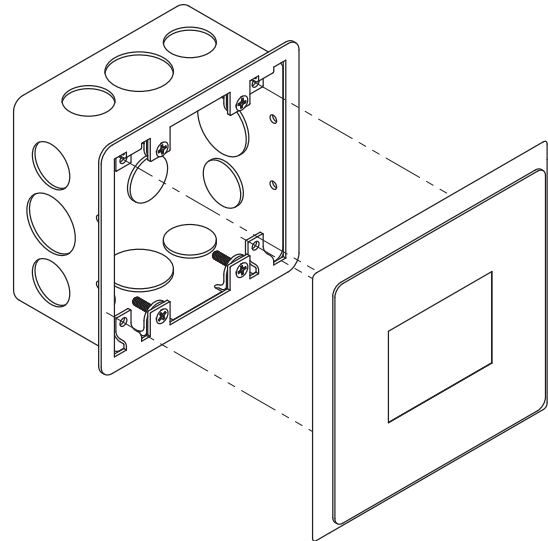

Room Sensor Mounting – If equipped

NOTE

Do not mount room sensor too close to the hood, too close to a cooking appliance, or on the ceiling. It should be mounted as close to chest height (roughly 60" AFF) as possible.

Room sensor may be provided with your equipment. It is PT1000 Ohm sensor, providing a real-time room temperature reading for the main control panel.

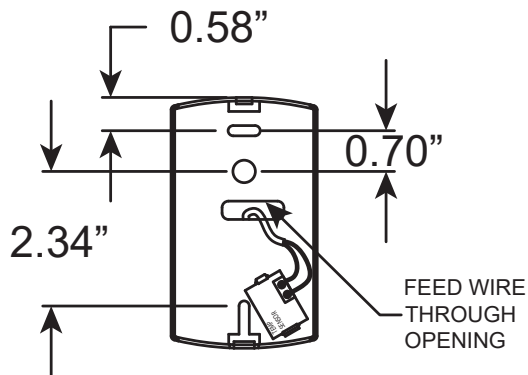
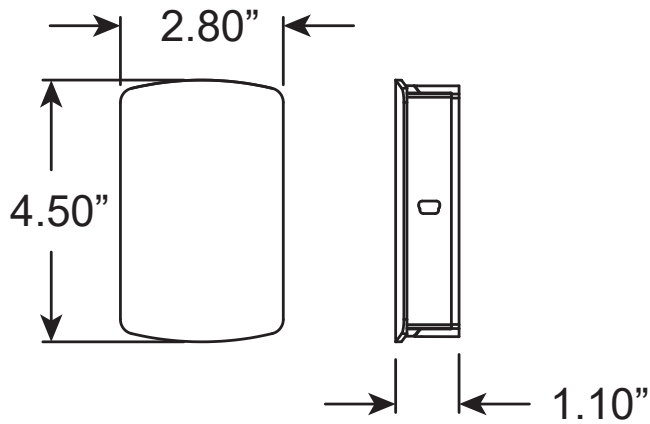

To mount room sensor:

1. Remove front cover from room sensor by pressing on tab on bottom of room sensor.
2. Route field provided 18ga - 22ga pair of low voltage wires from room sensor back to main control panel. See Electrical Connections section for information on where to connect the room sensor back to the main control enclosure.
3. Land each of the two wires on separate screws in the room sensor (not polarity sensitive).
4. Fasten the room sensor enclosure securely to wall (surface mount, fasteners by others).
5. Replace room sensor cover



Electrical Connections

All field wiring requirements for each panel will be shown on a sticker on the inside of the door of the panel.

Field connections may need to be connected to:

- Terminals blocks (open side), either on left side vertical din rail or top side horizontal din rail
- Direct to VFDs or motor starters
- Direct to screw terminals on left side of main printed circuit board (MB)

NOTE

All wiring of electrical equipment must be done to meet NEC and local codes.

NOTE

It is recommended that shielded wire be used for all low voltage connections (24 volts or less) to prevent signal interference with other high voltage circuits.

NOTE

All 115 VAC field wiring (or higher) must be routed through hard or flex conduit. All low voltage field wiring should be plenum rated if not routed through conduit. Field wiring should not come in contact with the surface of the hood. To reduce the likelihood of electromagnetic disturbance, avoid routing high and low voltage cables in the same conduit.

KITCHEN CONTROLS PANEL LAYOUT - ALL OPTIONS

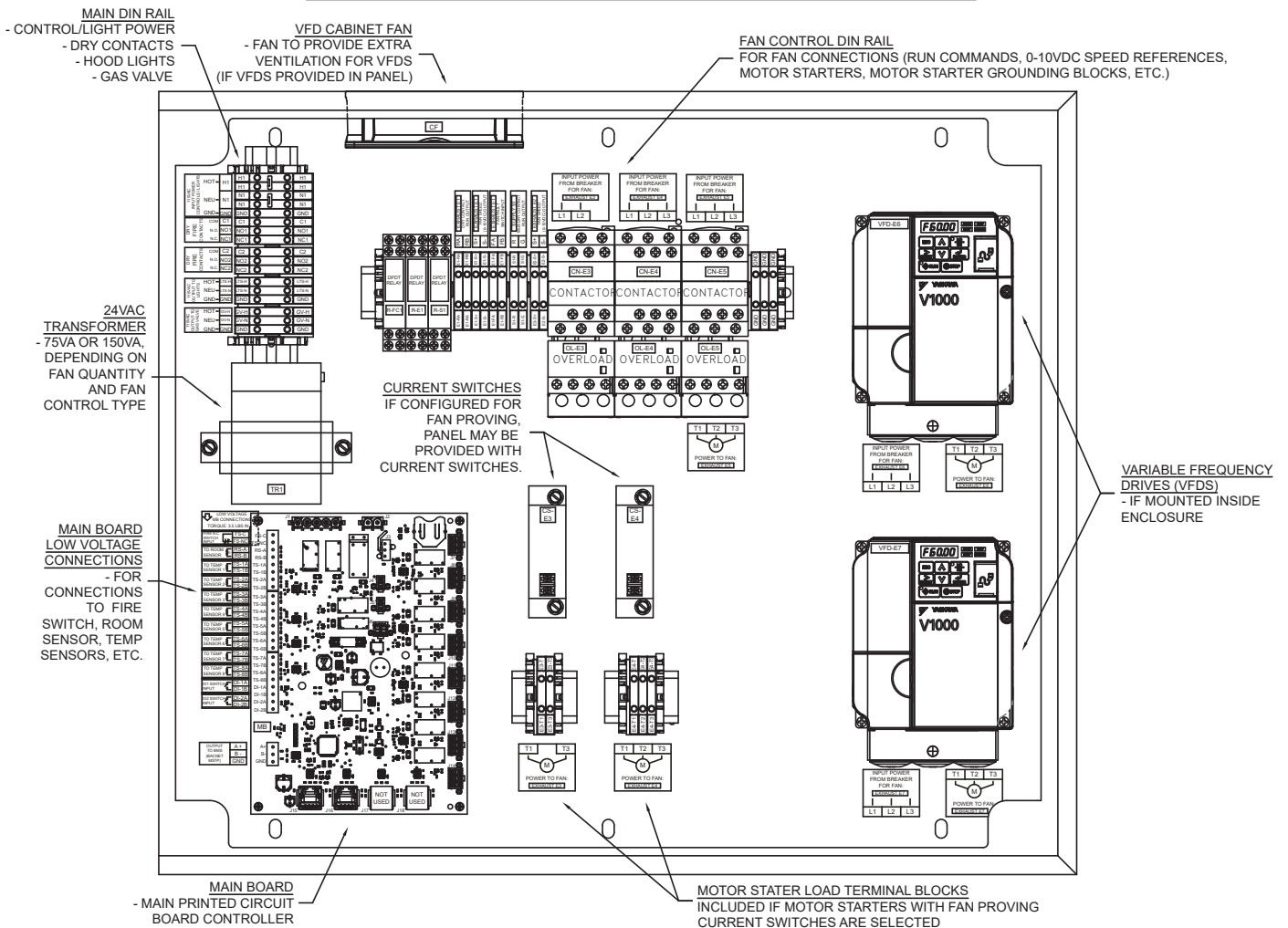

Power for Controls/Lights

115VAC or 230VAC 50/60Hz 1Phase (see job-specific wiring diagram for panel power/hood light requirement). Land hot on terminal block H1, land neutral on terminal block N1, and land ground on terminal block GND. This should come from non-shunted 15A building breaker.

Example:

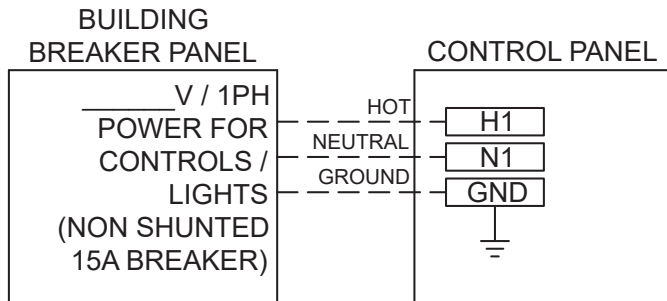

Hood Lights – If equipped

Hood lights (115VAC or 230VAC, see job-specific wiring diagram for light power information) should be wired in parallel and should be wired to terminal blocks LTS-H (hot), LTS-N (neutral), and GND (ground).

NOTE

Hood light load should not exceed 1200W.

Example:

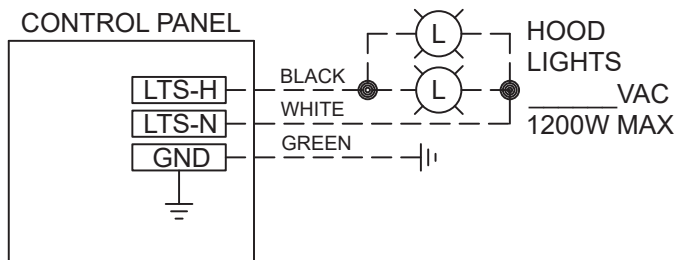

Fire System Dry Contacts

Fire system dry contacts are provided for controlling external devices, such as shunt trip breakers and/or appliance contactors that need to know when the fire system wet chemical has been released. These contacts will only function if fire system switch (common and normally-closed) is wired to terminals FS-C and FS-NC on the main board (MB).

- Terminal block C1 - Common
- Terminal block NO1 – Normally Open
- Terminal block NC1 – Normally Closed

If provided with additional fire contacts, a second identical dry set is provided:

- Terminal block C2 - Common
- Terminal block NO2 – Normally Open
- Terminal block NC2 – Normally Closed

Example:

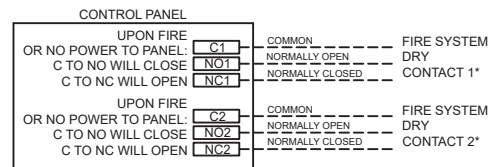

*FIRE SYSTEM DRY CONTACT WIRING EXAMPLES

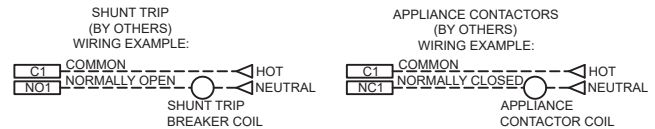

NOTE

Do not use these contacts for providing signals to the building fire alarm panel, as they will also switch state if power is ever lost to the control panel. Use separate spare fire system switch instead (mounted in fire suppression release).

NOTE

Do not use these contacts for shunt trip breakers and/or appliance contactors if the jobsite will experience frequent brownouts or blackouts. Use a spare fire system switch instead (mounted in the fire suppression release).

NOTE

Contacts rated for 8A and 250VAC max.



Motor Starter – If equipped

If motor starters are provided, input power from breaker should land directly on top of motor starter (L1 and L2 if single phase, or L1, L2, L3 if three phase). Power to fan should land directly on bottom of motor starter (T1 and T3 if single phase, or T1, T2, T3 if three phase). To help determine what fan gets wired to what motor starter, fan type and fan mark will be shown on the diagram.

Single Phase Example:

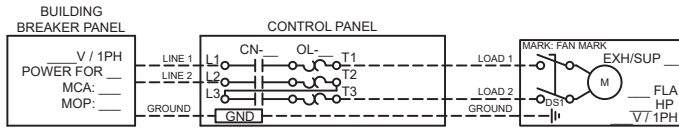

Three Phase Example:

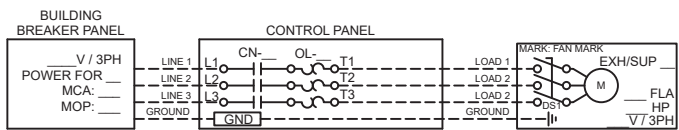

If fan proving sensor was provided for the fan, then power to fan should land on terminal blocks E/S_-T1 and E/S_-T2 if single phase, or terminal blocks E/S_-T1, E/S_-T2, E/S_-T3 if three phase.

Single Phase Example (with Fan Proving Sensor):

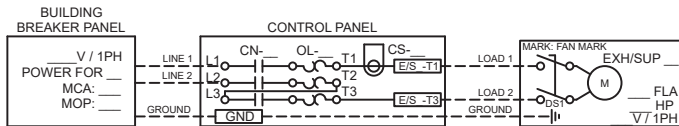

Three Phase Example (with Fan Proving Sensor):

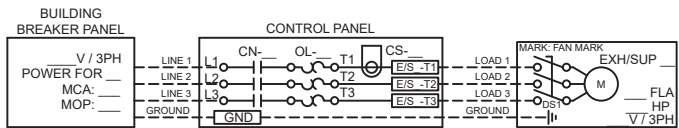

Motor Starter in MUA – If equipped

If controlling a Accurex constant volume MUA unit that's provided with a motor starter, the MUA power should be directly fed from building breaker to MUA unit disconnect. Low voltage wire should be run between control panel and MUA unit to control start/stop. Specifically, terminal blocks S_-R and S_-G in control panel should be connected to terminal blocks R and G in the MUA unit control center.

Example:

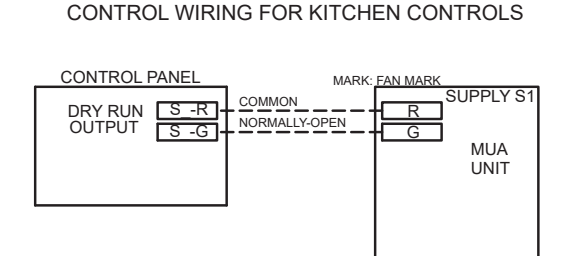
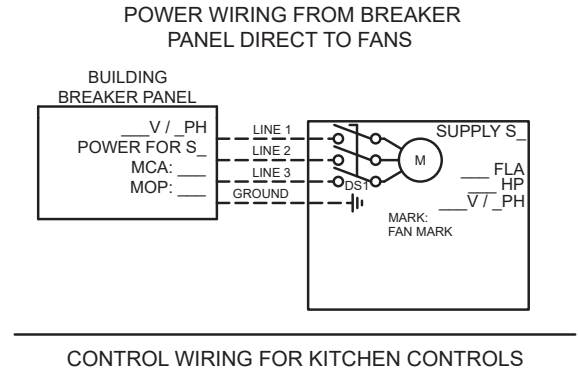

NOTE

If control panel is configured with fan proving, an additional fan proving (low voltage) contact may need to be connected from MUA control center to control panel. Specifically, terminal blocks S_-67 and S_-68 in control panel should be connected to terminal blocks 67 and 68 in the MUA unit control center. See "Fan Proving" section for more information.

Motor Starter by Others – If equipped

If controlling a motor starter provided in the field, the control panel will be equipped with a dry contact that closes when the motor starter should run the fan.

Example:

CONTROL WIRING FOR KITCHEN CONTROLS

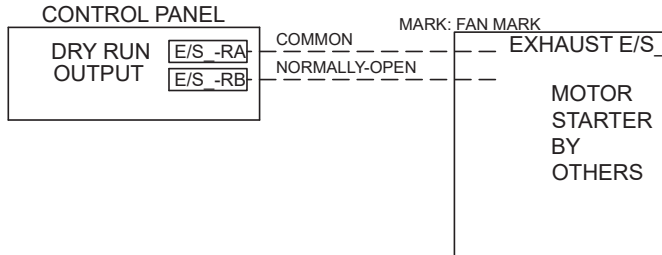

NOTE

Contacts rated for 8A and 250VAC max.

NOTE

If control panel is configured for fan proving, a current switch may also be provided in the panel, so that a hot leg for fan power needs to be routed through the current switch in order to detect fan operation. See “Fan Proving” section for more information.

VFD – If equipped

WARNING

Do NOT connect the AC line power to the output motor terminals (T1, T2, T3) of the drive. Failure to comply could result in death or serious injury by fire and permanent drive damage. Replacement drives will not be covered under warranty if miswired in this way.

NOTE

Motor wires from each VFD to their respective motor must be run in separate steel conduit, away from control wiring and incoming AC power to avoid noise and interference.

If VFDs are provided, input power from breaker should land directly on left side of VFD (L1 and L2 if single phase input, or L1, L2, L3 if three phase input). Power to fan should land on directly on right side of VFD (T1, T2, T3). To help determine what fan gets wired to what VFD, fan type and fan mark will be shown on the diagram.

Single Phase Input Example:

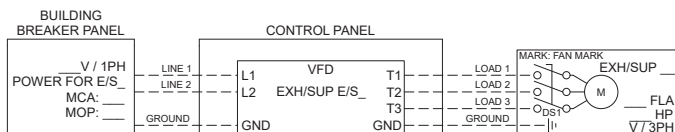

Three Phase Input Example:

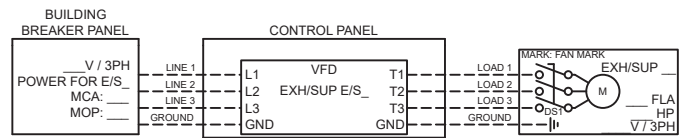

NOTE

If VFD is controlling a MUA unit that has a control center, an additional control power and a start/stop signal may be required. See “Motor Starter in MUA” section for information.

VFD in MUA – If equipped

If controlling a Larkin MUA unit that’s provided with a VFD, the MUA power should be directly fed from building breaker to MUA unit disconnect. Low voltage wire should be run between control panel and MUA unit to control start/stop and speed reference. Specifically, terminal blocks S_{-R} and S_{-G} in control panel should be connected to terminal blocks R and G in the MUA unit control center to control start stop, and terminal blocks S₋₄₆ (0-10VDC positive) and S₋₄₇ (common) should be connected to terminal blocks 46 and 47 in the MUA unit control center to control speed reference.

Example:

POWER WIRING FROM BREAKER PANEL DIRECT TO FANS

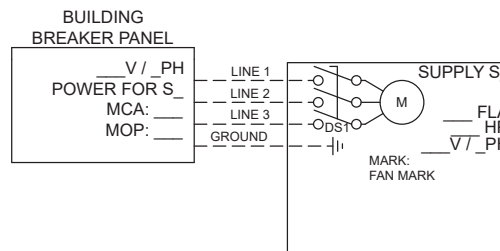

CONTROL WIRING FOR KITCHEN CONTROLS

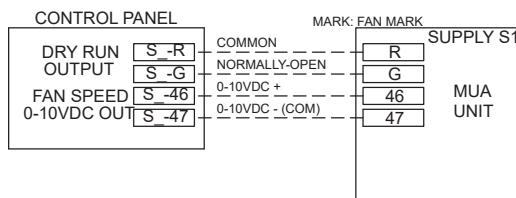

NOTE

If control panel is configured with fan proving, an additional fan proving (low voltage) contact may need to be connected from MUA control center to control panel. Specifically, terminal blocks S₋₆₇ and S₋₆₈ in control panel should be connected to terminal blocks 67 and 68 in the MUA unit control center. See “Fan Proving” section for more information.



VFD by Others – If equipped

If controlling a VFD provided in the field, the control panel will be equipped with:

- 1) A dry contact that closes when the motor starter should run the fan (terminal blocks E/S_-RA and E/S_-RB),
- 2) A fan fault input that when it detects it is closed will notify the system that the VFD is in fault (terminal blocks E/S_-FA and E/S_-FB), and if configured for variable volume,
- 3) A 0-10VDC speed reference (terminal blocks E/S_-S+ and E/S_-S-).

Constant Volume Example:

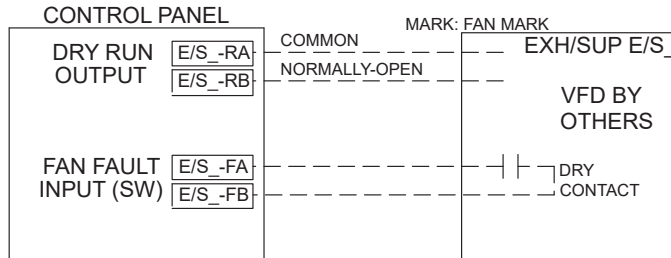

Variable Volume Example

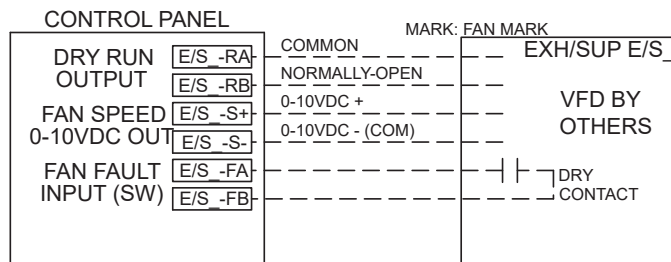

NOTE

Dry contacts (E/S_-RA and E/S_-RB) rated for 8A and 250VAC max.

NOTE

If control panel is configured for fan proving, a current switch may also be provided in the panel, so that a hot leg for fan power needs to be routed through the current switch in order to detect fan operation. See “Fan Proving” section for more information.

Vari-Green – If equipped

If controlling a Accurex fan that has a Vari-Green (VG) ECM motor, the fan power should be directly fed from building breaker to fan unit disconnect. Low voltage wire should be run between control panel and MUA unit to control speed reference. Specifically, terminal blocks E/S_S+ (0-10VDC positive) and E/S_-S- (common) should be connected to Vari-Green motor harness red and white wires, respectively.

Example:

POWER WIRING FROM BREAKER PANEL DIRECT TO FANS

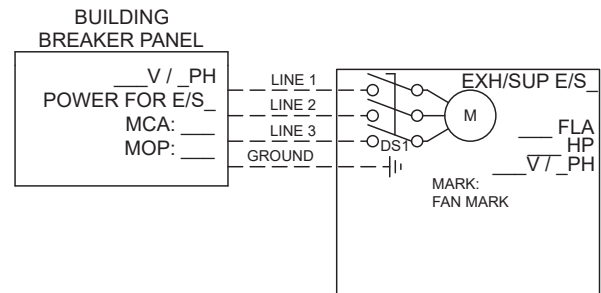

CONTROL WIRING FOR KITCHEN CONTROLS

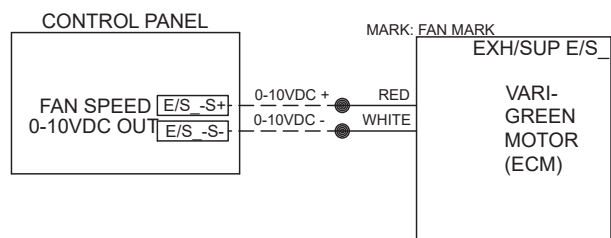

NOTE

If the Vari-Green motor being controlled is located in a MUA unit with a control center, then terminations will be similar to “VFD in MUA” section.

NOTE

If control panel is configured for fan proving, a current switch may also be provided in the panel, so that a hot leg for fan power needs to be routed through the current switch in order to detect fan operation. See “Fan Proving” section for more information.

NOTE

If control panel is configured with fan proving, an additional fan proving (low voltage) contact may need to be connected from MUA control center to control panel. Specifically, terminal blocks S_-67 and S_-68 in control panel should be connected to terminal blocks 67 and 68 in the MUA unit control center. See “Fan Proving” section for more information.

Vari-Green Drive – If equipped

If controlling a Accurex fan that has a Vari-Green Drive (VGD), the fan power should be directly fed from building breaker to fan unit disconnect. Low voltage wire should be run between control panel and MUA unit to control speed reference. Specifically, terminal blocks E/S_S+ (0-10VDC positive) and E/S_-S- (common) should be connected to Vari-Green Drive terminals AI and SG, respectively.

Example:

POWER WIRING FROM BREAKER PANEL DIRECT TO FANS

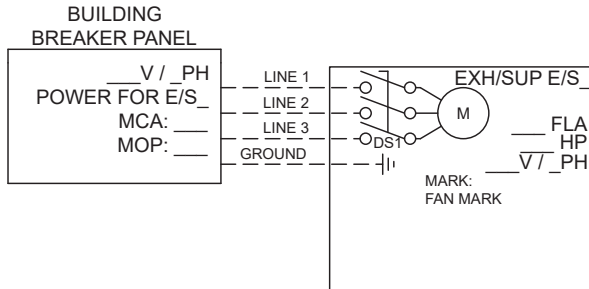

CONTROL WIRING FOR KITCHEN CONTROLS

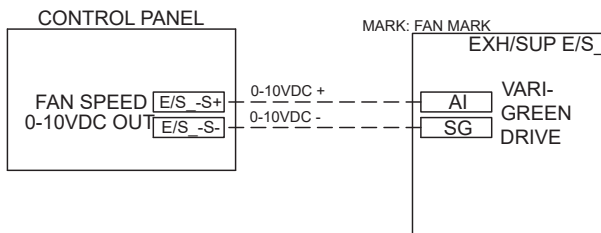

NOTE

If control panel is configured for fan proving, a current switch may also be provided in the panel, so that a hot leg for fan power needs to be routed through the current switch in order to detect fan operation. See “Fan Proving” section for more information.

Fire Suppression Fire System Switch – If equipped

Type I hood systems may be equipped with a fire suppression system, which requires specific fan operation when a fire occurs. The fire suppression release will typically be equipped with either snap-action mechanical fire micro-switches, or a relay module provided with dry switch contacts. If using the fire suppression switch input, remove the jumper first before wiring in actual fire switch. Otherwise, leave the jumper installed if not using the fire suppression switch input.

If tying in one single fire suppression system to one control panel, tie common and normally-closed to FS-C and FS-NC on the main board (MB) in the control panel.

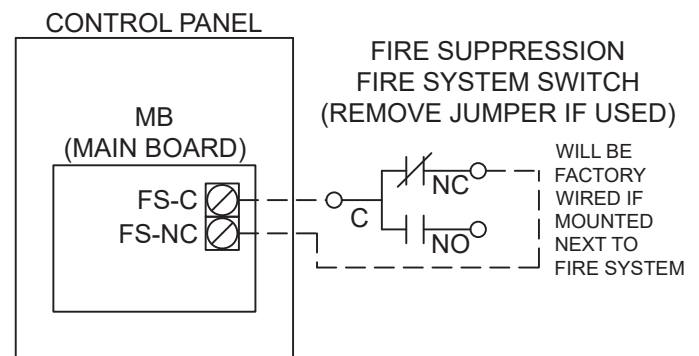

If tying in multiple fire suppression systems to one control panel, wire a series circuit loop between fire suppression systems, using normally closed contact on each fire suppression system switch.

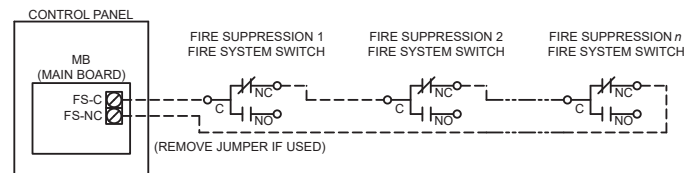

NOTE

FS-C and FS-NC should tie into DRY normally closed contact that OPENS during fire. DO NOT put any voltage onto these terminals from an external source, as this will damage the main board and replacement board will not be covered under warranty in this case.



Room Sensor – If equipped

Room sensor, if provided, will be shipped loose for remote mounting. Run 18ga – 22ga pair of low voltage wires (provided in field) from room sensor (terminate on two screws inside) to control panel and land on main board terminals RS-A and RS-B. Sensor is not polarity sensitive.

Hood Temperature Sensors – If equipped

Wire hood temp sensors back to individual TS-_A and TS-_B terminals using 18ga – 22ga pair of low voltage wires (provided in field). Sensors are not polarity sensitive.

NOTE

Some hood temperature sensors may be wired by the factory if the control panel is mounted in a utility cabinet on the hood.

Example:

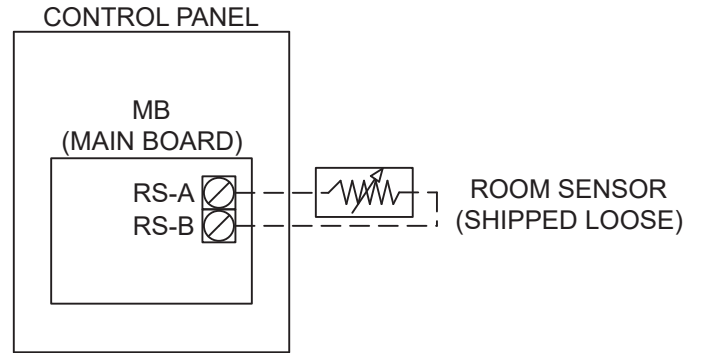

Example:

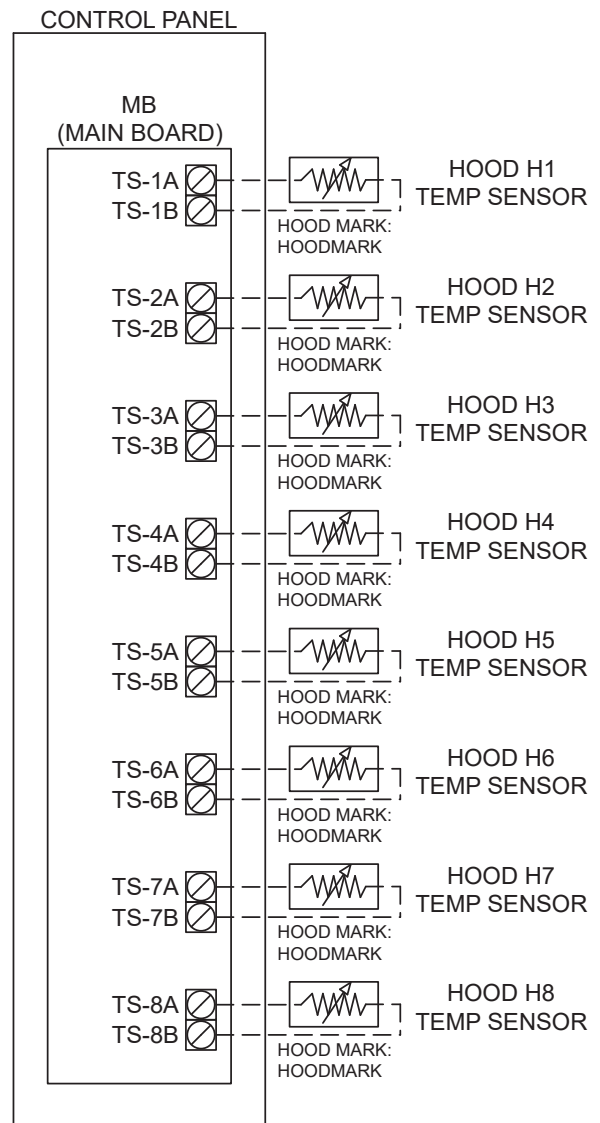

Digital Inputs – Optional

Two digital inputs are available to initiate control upon closure detected between terminals. These can be used by BMS or an external switch or control as needed. Digital input 1 will be terminals DI-1A and DI-1B on main board in control panel. Digital input 2 will be terminals DI-2A and DI-2B on main board in control panel.

Example:

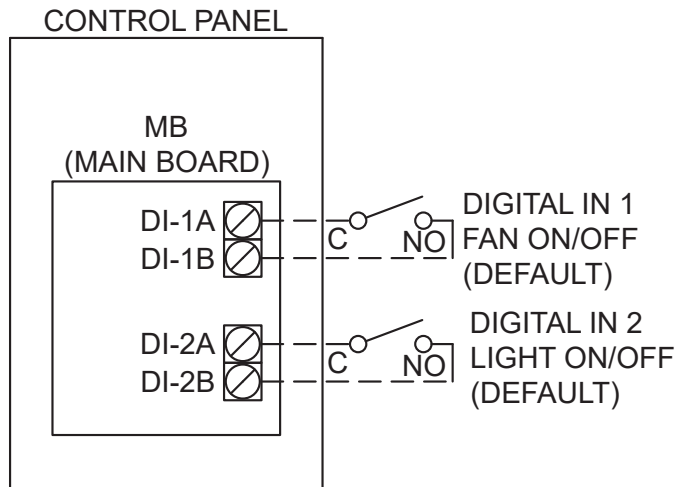

Digital Input Control Options	
Option	Description (when closed)
All Fans Enabled	Turn on all exhaust and supply fans (all zones) (DEFAULT FOR DI1)
All Lights Enabled	Turn on main board light circuit (DEFAULT FOR DI2)
All Lights and Fans Enabled	Turn on all exhaust/supply fans and main board light circuit
Max Fan Enable	All fans that are on will be forced to full speed (if not already at full speed). This setting only applies with VAV systems.
Zone 1 Fan Enable	Turns on all fans in zone 1
Zone 2 Fan Enable	Turns on all fans in zone 2
Zone 3 Fan Enable	Turns on all fans in zone 3
Zone 4 Fan Enable	Turns on all fans in zone 4
Zone 5 Fan Enable	Turns on all fans in zone 5
Zone 6 Fan Enable	Turns on all fans in zone 6
Zone 7 Fan Enable	Turns on all fans in zone 7
Zone 8 Fan Enable	Turns on all fans in zone 8
Exhaust Fan 1 Enable Only	Turns on exhaust fan E1 <u>only</u> (and ramps to full speed, if variable volume)
Exhaust Fan 2 Enable Only	Turns on exhaust fan E2 <u>only</u> (and ramps to full speed, if variable volume)
Exhaust Fan 3 Enable Only	Turns on exhaust fan E3 <u>only</u> (and ramps to full speed, if variable volume)
Exhaust Fan 4 Enable Only	Turns on exhaust fan E4 <u>only</u> (and ramps to full speed, if variable volume)
Exhaust Fan 5 Enable Only	Turns on exhaust fan E5 <u>only</u> (and ramps to full speed, if variable volume)
Exhaust Fan 6 Enable Only	Turns on exhaust fan E6 <u>only</u> (and ramps to full speed, if variable volume)
Exhaust Fan 7 Enable Only	Turns on exhaust fan E7 <u>only</u> (and ramps to full speed, if variable volume)
Exhaust Fan 8 Enable Only	Turns on exhaust fan E8 <u>only</u> (and ramps to full speed, if variable volume)
All Exhaust Fans Enable Only	Turns on all exhaust fans <u>only</u> (and ramps to full speed, if variable volume)
Supply Fan 1 Enable Only	Turns on supply fan S1 <u>only</u> (and ramps to full speed, if variable volume)
Supply Fan 2 Enable Only	Turns on supply fan S2 <u>only</u> (and ramps to full speed, if variable volume)
Supply Fan 3 Enable Only	Turns on supply fan S3 <u>only</u> (and ramps to full speed, if variable volume)
Supply Fan 4 Enable Only	Turns on supply fan S4 <u>only</u> (and ramps to full speed, if variable volume)
All Supply Fans Enable Only	Turns on all supply fans <u>only</u> (and ramps to full speed, if variable volume)
Kill Switch	Forces all fans off (unless kitchen fire is detected)

Building Management System (BMS) –

If equipped

Control package may be provided with Building Management System (BMS) interface, to give the BMS the ability to monitor/control points on the system.

If equipped with Modbus or BACnet® MSTP compatibility, wiring should be made directly to the main board (MB), on J23 port using twisted, shielded pair.

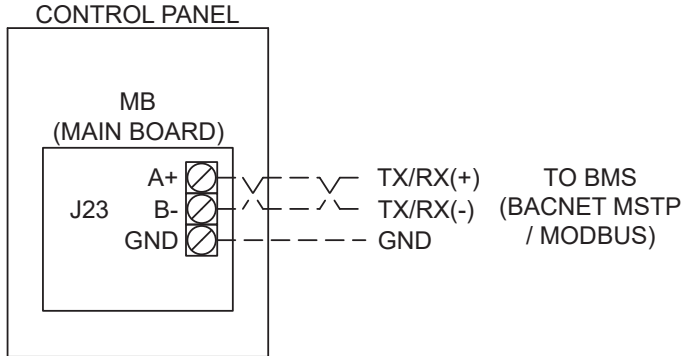

If equipped with BACnet IP compatibility, the system will be provided with a gateway. Connect using RJ45 CAT5 Ethernet wiring to gateway (GW1) ethernet port.

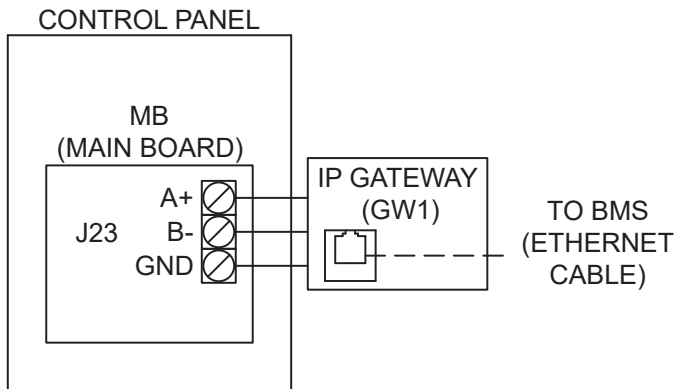

User Interface

User interface and user interface CAT5 cable will be factory provided, and may already be connected to the main control panel. If it is not, connect user interface back to main board (MB), from RJ45 port on the back of the user interface board to the main board J15 RJ45 port in the control panel. User interface factory provided cable will be CAT5, shielded, and plenum rated so it does not need to be routed through conduit.

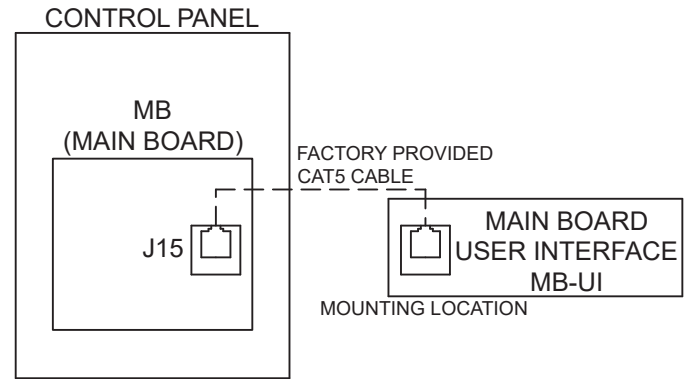

Fan Proving – If equipped

Fan proving current switches may be provided if the panel is configured for fan proving. Unless already done by factory, route one leg of fan power through the middle of the current switch. This is used to monitor fan power required per code for certain jurisdictions. Current switch will be labeled “CS-__”.

Example of VG/VGD with fan proving:

POWER WIRING FROM BREAKER PANEL DIRECT TO FANS

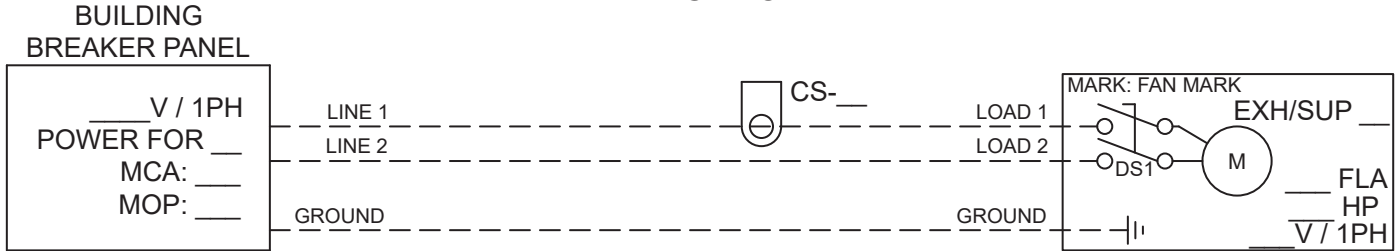

Current Switch Operation:

- 0.5A fixed set point
- If minimum operating current is less than 0.5A, wrap the conductor wire through the sensing hole and around the CCS body to produce multiple turns to increase the measured current above 0.5A. Measured current = actual current x the number of turns. For example, if fan is operating at 0.4A, turning conductor 2 times will produce 0.8A, which is greater than 0.5A and correctly show fan is proving. Required number of turns should be printed on the wiring diagram next to the CS current sensor.
- Red LED indicates set point has been reached and the contacts are now closed (fan is currently proving)

Occasionally, MUA unit will already have a fan proving airflow switch installed. In that case, low voltage wire should be tied from terminal blocks 67 and 68 in the MUA unit to terminal blocks S_-67 and S_-68 in the control panel.

Example of MUA with airflow proving contact:

CONTROL WIRING FOR KITCHEN CONTROLS

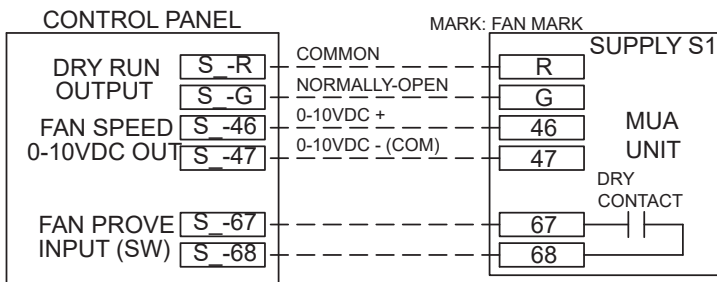

See “Settings Navigation – Factory Authorized Servicer” for more information on fan proving setup, parameters, and calibration.



Electrical Connection Checklist

Power for Controls/Lights

- 115 VAC or 230 VAC 1Phase power for controls/lights (terminals blocks H, N, GND)

Hood Lights – If equipped

- 115 VAC or 230 VA 1Phase to hood lights (terminals LTS-H, LTS-N, GND)

Fire System Dry Contacts

- Fire contact 1 for shunt trip/appliance contactor control (terminal blocks C1, NO1, NC1)
- Fire contact 2 for shunt trip/appliance contactor control (terminal blocks C2, NO2, NC2) – If equipped

Motor Starter – If equipped

- Line power to motor starter (terminals L1, L2 if 1 phase and L1, L2, L3 for 3 phase)
- Load power from motor starter (terminals T1, T3 if 1 phase and T1, T2, T3 for 3 phase)
- If equipped with fan proving, load power from terminal blocks E/S_-T1, E/S_-T3 or E/S_-T1, E/S_-T2, E/S_-T3)

Motor Starter in MUA – If equipped

- Line power direct to MUA unit disconnect
- Low voltage to R and G in MUA (terminals S_-R and S_-G in kitchen controls)

Motor Starter by Others – If equipped

- Line/load power direct to motor starter provided in field
- Dry, normally-open contact provided to engage motor starter (terminals E/S_-RA, E/S_-RB)

VFD – If equipped

- Line power to VFD (terminals L1, L2 if 1 phase and L1, L2, L3 for 3 phase)
- Load power from VFD (terminals T1, T2, T3)

VFD in MUA – If equipped

- Line power direct to MUA unit disconnect
- Low voltage to R, G, 46, 47 in MUA (terminal S_-R, S_-G, S_-46, S_-47 in kitchen controls)

VFD by Others – If equipped

- Line/load power direct to VFD provided in field
- Dry, normally-open contact provided to engage motor starter (terminals E/S_-RA, E/S_-RB)
- Fan fault digital input to detect VFD fault (terminals E/S_-FA, E/S_-FB)
- If variable volume, 0-10VDC speed reference (terminals E/S_-S+, E/S_-S-)

Vari-Green – If equipped

- Line power direct to fan disconnect
- Low voltage to red and white wires on Vari-Green motor (terminals E/S_-S+ and E/S_-S- in kitchen controls)

Vari-Green Drive – If equipped

- Line power direct to fan disconnect
- Low voltage to AI and SG on Vari-Green drive (terminals E/S_-S+ and E/S_-S- in kitchen controls)

Fire Suppression Fire System Switch – If equipped

- Common on switch to FS-C on main board
- Normally-closed on switch to FS-NC on main board

Room Sensor – If equipped

- Low voltage 2-wire from room sensor (terminals RS-A and RS-B on main board in kitchen controls)

Hood Temperature Sensors – If equipped

- Sensor 1 (TS-1A and TS-1B on main board in kitchen controls)

If more than one temperature sensor is used, wire the following if applicable:

- Sensor 2 (TS-2A and TS-2B on main board in kitchen controls)
- Sensor 3 (TS-3A and TS-3B on main board in kitchen controls)
- Sensor 4 (TS-4A and TS-4B on main board in kitchen controls)
- Sensor 5 (TS-5A and TS-5B on main board in kitchen controls)
- Sensor 6 (TS-6A and TS-6B on main board in kitchen controls)
- Sensor 7 (TS-7A and TS-7B on main board in kitchen controls)
- Sensor 8 (TS-8A and TS-8B on main board in kitchen controls)

Digital Inputs – Optional

- Digital input 1 (DI-1A and DI-1B on main board in kitchen controls) – Default to Fan On/Off
- Digital input 2 (DI-2A and DI-2B on main board in kitchen controls) – Default to Light On/Off

BMS – If equipped

- Twisted shield pair from network to J23 port on main board (for Modbus or BACnet MSTP)
- RJ45 CAT5 Ethernet cable from network to gateway GW1 (for BACnet IP)

User Interface (UI)

- Connect factory provided CAT5 cable from UI to J15 port on main board.

User Interface (UI) Operation – End User

General End User Operation

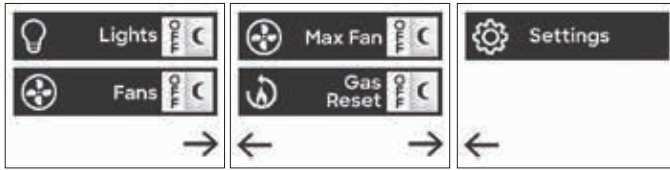

User interface (UI) consists of a resistive full-color touchscreen. For general operation, it's main purpose is to turn on and off hood ventilation and hood lights, depending on the configuration, via the main screens. It's also used by factory authorized servicicers to adjust settings and diagnose problems (if necessary) using a password protected system settings navigation.

NOTE

Some buttons shown below may not apply to your specific configuration.

Only one (1) user interface can be connected to the main board.

Up to two (2) buttons can fit on each main screen, with right/left arrows providing navigation to additional control buttons.

1) Fans

- Pressing Fans will either –
 - turn on all fans if configured for a single zone, or
 - navigate to an additional menu to be able to turn on fans for individual zones if configured for multiple zones.

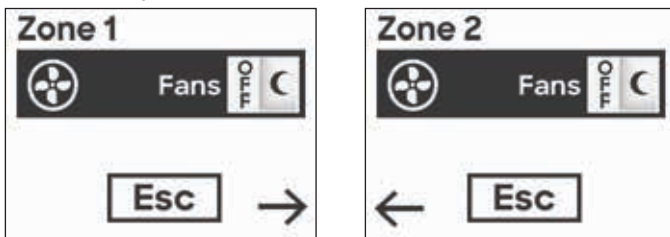

Example of 2-zone configuration, when pressing Fans button on main screen.

- When any fan is on (due to any reason like fan button being pressed, cooking temperatures being detected, digital input configured for fans is closed, etc.), the fan icon will be orange and show ON.

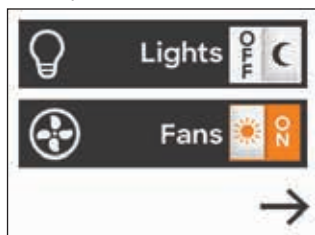

Example of Fans button when any fan is on.

- Pressing Fans button again will turn the fans off, unless something else is preventing the fans from shutting off (see previous).
- If fans cannot be shut off via the button, the user interface will display a message explaining why the fan(s) cannot be shut off.

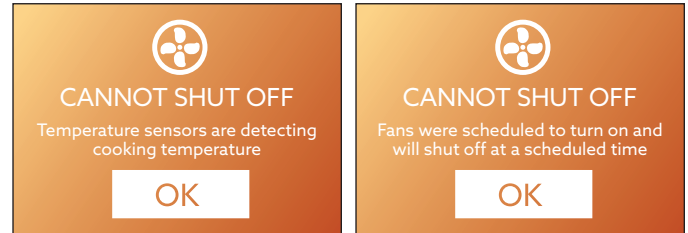

Example of screens showing reason why fan(s) cannot shut off.

- Once all fans are off, Fans button will be gray and show OFF.

2) Lights

- Pressing the Lights button will turn on the hood lights.
- When lights are on (due to any reason like light button being pressed, digital input closing, etc.) the Lights button will be orange and show ON.

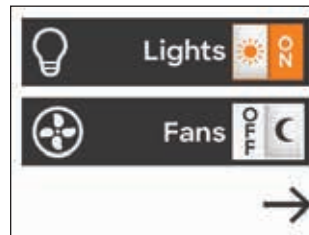

Example of Lights button when hood lights are on.

- Pressing Lights button again will turn the lights off, unless something else is preventing the lights from shutting off (see previous).
- Once lights are off, Lights button will be gray and show OFF.

3) Max Fan

- Pressing Max Fan will ramp all fans that are already on to full speed for a specific time. Once time has expired, Max Fan will shut off. Max fan can be turned off manually before this timer expires by pressing the button again.
- If Max Fan is on, Max Fan button will show ON.
- This option can only be configured for variable volume systems.

4) Gas Reset

- Pressing gas reset will engage the gas valve relay and unlock the gas valve. Once the gas valve is unlocked, it cannot/will not be shut off unless there is a fire, detection of high temperature (if configured), or power is cycled to the panel.
- If gas valve is unlocked, Gas Reset button will show ON.

NOTE

Buzzer on the UI may sound three times if buzzer is enabled. A prompt will be displayed stating to relight all standing pilots on cooking equipment.

NOTE

Gas Reset operation may be configured to follow fans. This means whenever fans are shut off, this gas valve relay will disengage and shut of the gas to the cooking equipment. If this is configured, the user will need to press the gas reset button after turning fans on each time they are turned on to use the cooking equipment.

5) Settings

- Pressing the settings buttons will allow access into all system settings.

NOTE

Entering into system settings and adjusting settings should only be done by factory authorized servicer or with direction by the factory. This should not be done by day-to-day kitchen operators, unless guided by factory.

Faults

If a fault is present on the system:

- Fault button will replace the time/date on the main screens
- Buzzer may sound (if buzzer is enabled) on UI in 1 second intervals. Buzzer will stop sounding automatically when issue causing the fault is corrected.

NOTE

Buzzer can be muted by pressing anywhere on the UI.

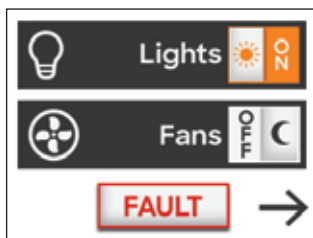

Example showing main screen with fault present on system.

See troubleshooting section to help determine/fix the fault issue, or contact Accurex for technical assistance.

Upon detection of a fire (through the connection to fire suppression fire switch), screen will display FIRE DETECTED and will not escape this screen until fire system is reset.



Example of UI if fire detected.

WARNING

Upon a kitchen fire, evacuate the facility immediately and contact your local fire department, unless already dispatched.

Pressing the fault button on the UI will enter into a current fault screen displaying all faults currently on the system.

Fault Displayed	Fault Description
Fire Detected	Indicates a kitchen fire is detected
High Temp	Indicates high hood temperature
Freeze Protection	Indicates low hood temperature
Fan (J4 DI)	Indicates fan fault(s) detected (motor starter or VFD by others)
VFD Alarm	Indicates VFD(s) currently in fault
VFD Communication	Indicates a loss of communication to the VFD(s)
Temp Sensor Error	Indicates faulty connection to or failed room or hood temp sensor(s)
Sup. Fan Not Proving	Indicates supply fan failed to prove (see Fan Proving)
Sup. Fan Proving Loss	Indicates supply fan failed to prove during operation (see Fan Proving)
Exh. Fan Not Proving	Indicates exhaust fan failed to prove (see Fan Proving)
Exh. Fan Proving Loss	Indicates exhaust fan failed to prove during operation (see Fan Proving)
Proving Calib. Failed	Indicates fan calibration test has failed (see Fan Proving)
Kill Switch	Indicates digital input configured for Kill Switch function has been closed and fans have been forced off.

NOTE

All faults will automatically clear, except for fan proving faults. Fan proving faults need to be manually cleared by pressing the RESET button at the bottom of the current faults screen.



Example of current faults screen, with RESET button



Settings Navigation – Factory Authorized Servicer

NOTE

Entering into system settings and adjusting settings should only be done by factory authorized servicer or with direction by the factory. This should not be done by day-to-day kitchen operators, unless guided by factory.

NOTE

It is suggested that after changing any parameters in the system settings, cycle power to the control panel before operating.

To enter into the systems settings, press Settings button and enter service password (default 1000). Once password is entered and displayed correctly on the screen, press the arrow pointing to the right.

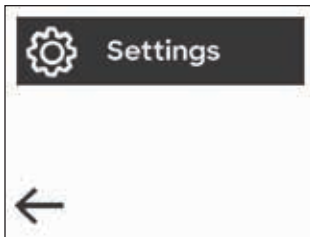

Example of Settings button

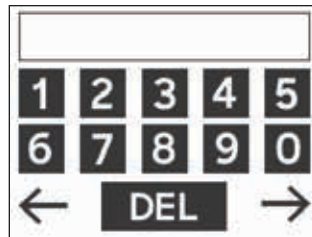

Example of password prompt screen

Settings are broken into these 14 sub-menus. Some may not be visible based on the configuration.

- 1) Factory Settings – Include setting hood, fan, sensor quantities and determining main configuration aspects for the system.
- 2) Zone Settings – Include settings for each zone configured, such determining temperature interlock set points
- 3) Hood Settings – Includes settings for each hood configured, such as determining which exhaust fan configured on the system is linked to which hood
- 4) Exhaust Fan Settings – Includes settings for each exhaust fan, such as min/max CFM
- 5) Supply Fan Settings – Includes settings for each supply fan, such as min/max CFM
- 6) Sensor Settings – Includes settings for each hood temp sensor, such as determining which sensor configured on the system is linked to which hood
- 7) User Interface Settings – Includes settings for the user interface, such as enabling/disabling the UI buzzer operation
- 8) General Settings – Includes general settings such as date/time adjustment and language
- 9) Fan Scheduling – Submenu for setting up fan on/off schedules
- 10) Fire/Fault Settings – Includes settings that determine fan/light operation during fire

- 11) Diagnostics – Submenu to assist with diagnosing problems, such as viewing real time temp sensor values
- 12) Fan Proving – Includes fan calibration test
- 13) Digital Input Settings – Includes settings for controlling digital inputs DI-1A/DI-1B and DI-2A/DI-2B on main board.
- 14) BMS Settings – Settings for building management system interfacing

Example of Changing a Setting

- 1) For this example, we want to change Max VDC on Exhaust Fan 2 from 10.0 down to 9.5 VDC for fan balancing purposes. After pressing Settings button and successfully entering the password, we enter into the system settings where “Factory Settings” is the first menu to show on the screen:



- 2) Scroll up/down to “Exhaust Fan Settings” and press Enter button to enter into Exhaust Fan Settings.



- 3) Press up/down until reaching “Exhaust Fan 2”, and \ press Enter button.

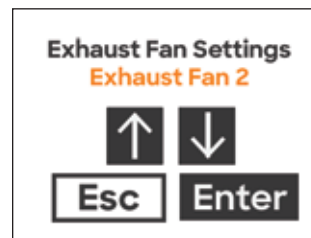

- 4) Scroll up/down until reaching “Max VDC”, and press Enter button.

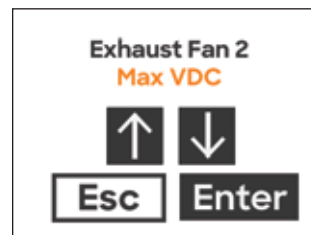

- 5) Adjust value from 10.0 VDC to 9.5 VDC, then press Enter to store value. If successful, screen will show “Saved”.



- 6) Press Escape button until back to main screens (or wait as screen will automatically revert back to main screens if no one touches the screen after UI Dimming Delay timer expires).

Factory Settings

Type - *Default set by factory*

- Select either CV (Constant Volume) or VAV (Variable Volume)
 - CV – Fans are either off or on, they will not vary with respect to cooking operation
 - VAV – Fans that are on will vary with respect to cooking operation

Configuration - *Default is standard*

- Select either Standard or Advanced

Zones - *Default set by factory*

- Select number between 0 and 8
- Zone is a combination of exhaust fans, supply fans, and hoods (temp sensors). A zone requires at least one exhaust fan and one hood.

Hoods - *Default set by factory*

- Select number between 0 and 8
- Quantity of hoods controlled by system

Exhaust Fans - *Default set by factory*

- Select number between 0 and 8
- Quantity of exhaust fans controlled by system

Supply Fans - *Default set by factory*

- Select number between 0 to 4

MB (Main Board) Room Sensor - *Default set by factory*

- Select from either “No” or “Yes”
- This enables the room sensor input “RS-A” and “RS-B”. Room temperature sensor reads in room temperature, compares it with the hood temperature sensors in that zone, and turn on the fans in that zone automatically if temperatures exceed a threshold over the room temperature (see zone temp interlock offset). Room sensor is allocated to specific zone or zones. This is done in the Zone Settings.

MB (Main Board) Temp Sensor - *Default set by factory*

- Select number from 0 to 8.

- This allocates the 8 hood temp sensor inputs “TS-1A/TS-1B” through “TS-8A/TS-8B”. Hood sensors are responsible for either comparing their temps with the room temp in that zone, or a preset temp, and once exceeding a span turns the fans in that zone on automatically. With VAV type systems, they are also responsible for speeding up/slowing down the fan based on a temperature range.

High Temp Fault - *Default set by factory*

- Select from either “No” or “Yes”
- Selecting “Yes” will do the following upon any hood temp sensor exceeding the high temp fault set point (see general settings for adjusting this value)
 1. Switch state of fault contacts (if fault contacts assigned as shunt trip)
 2. Switch state of gas valve contacts (if gas reset is enabled).
 3. Trigger a High Temperature Fault on system

Freeze Protection - *Default is “Yes”*

- Select from either “No” or “Yes”
- Selecting “Yes” will do the following upon any hood temperature falls below the freeze protection set point (see general settings for adjusting this value)
 1. Turn on all fans assigned to the hood temperature zone and (if VAV) run at full speed
 2. Trigger a Freeze Protection Fault on system

Gas Reset - *Default set by factory*

- Select from either “No” or “Yes”
- Selecting “Yes” will populate UI with “Gas Reset” button and gas valve control (see Gas Reset in User Interface Operation).

Fan Proving - *Default set by factory*

- Select from either “No” or “Yes – Supply Only” or “Yes – Exhaust and Supply”
- This setting provides a means to interlock fan operation based on local code. Some jurisdictions require supply fans to prove air (and continue to prove air) for exhaust to run. Other jurisdictions require both to prove they are running simultaneously using timers.
- Fan monitoring is done using either current sensor switches, or if provided with VFDs through VFD communication to main board.
- If set to “Yes – Supply Only”
 - Upon all fans in a zone being told to run (manually or automatically), the supply fans are activated first. They are given a maximum of 90 seconds to prove. If the supply fans are not passing their airflow proving threshold in that 90 seconds, supply fans will be shut off and fault will occur. If the supply fans successfully pass their airflow proving threshold successfully, exhaust fans will be activated for that zone.



- Once all fans are successfully on, the system will monitor for supply airflow proving loss. If there is a loss of proving, this will trigger a timer. If there is a loss of proving for 15 consecutive seconds, a proving fault will occur, and all fans will shut off.
- If set to “Yes – Exhaust and Supply”
 - Upon all fans in a zone being told to run (manually or automatically), the supply fans are activated first. They are given a maximum of 90 seconds to prove. If the supply fans are not passing their airflow proving threshold in that 90 seconds, supply fans will be shut off and fault will occur. If the supply fans do pass their airflow proving threshold successfully, exhaust fans will be activated for that zone.
 - Next, the exhaust fans on that zone will be given a maximum of 90 seconds to prove. If the exhaust fans are not passing their airflow proving threshold in that 90 seconds, both exhaust and supply fans will be shut off and fault will occur.
 - If all exhaust fans running on the zone have passed their threshold, the system will monitor for a loss of proving. If there is a loss of proving on any fan, this will trigger a timer. If there is a loss of proving for 15 consecutive seconds, a proving fault will occur, and all fans will shut off.
- A few examples of why a fan would not be operating are: overload tripped, broken fan belt, defective motor, disconnect switch off, etc.
- To reset the system after a proving fault, press the “RESET” button in the current faults screen.

BMS - Default set by factory

- Select from either “None”, “Modbus”, or “BACnet MSTP”
- This configures the “BMS” J23 port on the main board to either Modbus or BACnet MSTP protocol. For BACnet IP protocol, a gateway GW1 is provided and this J23 port is wired to the gateway to convert Modbus to BACnet IP.
- Settings for BMS connection can be accessed in BMS settings on touchscreen.

Factory Reset

- Select from either “No” or “Yes”
- If selecting “Yes”, this will reset the controller to factory defaults.
- This is always set to “No” until manually changed to “Yes”, which starts a factory reset procedure.

Zone Settings



Confirm “Yes” to restore factory defaults

Settings restored confirmation screen

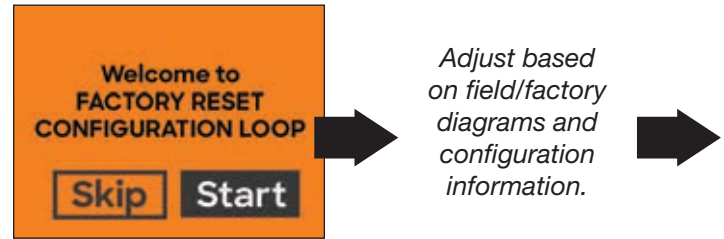

Prompt to start factory reset configuration loop

Adjust based on field/factory diagrams and configuration information.

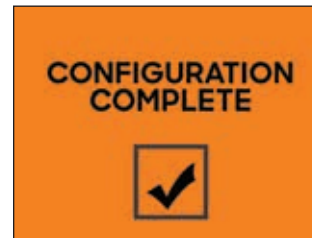

Configuration complete screen



Settings shown below will be provided for each zone configured.

Room Temp - Default set by factory

- Select “Preset” or “MB-RS”
 - Assigning this to “Preset” will compare hood temps in the zone selected to the Preset Room Temp setting that also lives in the zone settings for each zone. If a hood temp sensor in that zone raises above preset room temp plus zone temp interlock offset temp (see zone settings), it will turn the fans in that zone on.

- Assigning this to the actual MB-RS is the main board room sensor (terminals RS-A/RS-B), and the system will compare hood temps in the zone selected to the main board room sensor selected. If a hood temp sensor in that zone raises above main board room sensor temp plus temp interlock offset (see sensor settings), it will turn the fans in that zone on.

Preset Room Temp - Default is 75°F

- Select whole number between 50 to 80°F. See Room Temp setting above for information.

Min Room Temp - Default is 50°F

- Select whole number between 50 and 80°F.
- This will prevent the room temp value (if set to read in a main board room sensor) from falling below a certain point, if large fluctuations in temp occur in the kitchen. For example, if you set this setting for zone 1 to 60°F, and the room temp sensor drops below 60°F for zone 1, the controller will still see the value as a straight 60°F.

NOTE

Freeze protection still should be looking at all actual hood temps, even if they are below the min room temp set point.

Max Room Temp - Default is 100°F

- Select whole number between 80 and 120°F.
- This will prevent the room temp value (if set to read in a main board room sensor) from rising above a certain point, if large fluctuations in temp occur in the kitchen. For example, if you set this setting for zone 1 to 110°F, and the room temp sensor raises above 110°F for zone 1, the controller will still see the value as a straight 110°F.

Zone Temp Interlock Offset - Default is 10°F

- Select a whole number between 1 and 25°F.
- If any hoods in the zone exceed the room temp + zone temp interlock offset, the fans will not shut off automatically (assuming Auto Fan Off in General Settings is set to “Yes”) until hood temp drops room temp by a margin of the temp interlock hysteresis and remain below this value for the Temp Interlock Hysteresis Timer.

Temp Interlock Hysteresis - Default set to 5°F

- Select a whole number between 1 and 15°F.
- If any hoods in the zone exceeded the temp interlock offset, the fans will not shut off automatically (assuming Auto Fan Off in General Settings is set to “Yes”) until all hood temps in the zone are below the room temp (preset or actual) + zone temp interlock offset and remain below this value for the Temp Interlock Hysteresis Timer.

- For example, if room temp is 75°F and zone temp interlock offset is 10°F and temp interlock hysteresis timer is 5°F, after zone temp interlock offset was reached (at 75°F + 10°F = 85°F), fans will not shut down for that zone until sensors in hood drop below 85°F – 5°F = 80°F and remain there (or below) for the hysteresis timer expires.

Hysteresis Timer - Default set to 30 min.

- Select a whole number between 1 and 60 minutes.
- See Temp Interlock Hysteresis description above.

Max Fan Enabled

- This setting will only appear if the system type is set to VAV
- Select from either “No” or “Yes”
- If set to “Yes”, this provides “Max Fan” button on the user interface. When pressed, any fans **that are currently on** will temporarily ramp to full speed for the max fan time, unless the button is pressed again (which will turn off max fan prematurely).
- When configured for VAV, default for this is set to “Yes”.

Max Fan Time - Default is 10 min.

- This setting will only appear if the system type is set to VAV
- Select a whole number between 1 and 60 minutes.

Hood Settings



Settings shown below will be provided for each hood configured.

Exhaust Fan - Default set by factory

- Select a whole number between 0 and the max number of exhaust fans quantity configured in the factory settings.
- This assigns an exhaust fan to a single hood section. This helps provide a link between hood sensors and exhaust fans, as sensors will turn the fans linked to it on upon detecting cooking temperature (if temperature sensor exceeds room temp/preset temp + zone temp interlock offset (assigned to it) and also will modulate fan speed based on cooking temperature with VAV type panels (see modulation setting in exhaust fan settings).



Exhaust Fan Settings



Settings shown below will be provided for each exhaust fan configured.

Fan Number - Default set by factory

- Select whole number between 0 and 8
- This allocates a specific J7 through J14 port on board to this specific fan. For example, if exhaust fan 2 is allocated for fan number 2, then the J8 connector (24VAC relay, 0-10VDC, and if fan providing is enabled digital input on J8 connector) will be allocated for the exhaust fan 2 control.

Zone - Default set by factory

- Select whole number between 0 and 8
- This links the exhaust fan to a specific zone. The main board already knows which hoods are linked to what exhaust fans (hood settings), and also knows what sensors are linked to what hoods (sensor settings) are linked to what zones. Therefore, the main board knows what exhaust fans are linked to what temp sensors and also what zone. That way, if a hood temp sensor exceeds the room temp + zone temp interlock offset it turns the correct fan on automatically (if not already on). Also, if panel type is set to VAV, at this point the main board can compare the fan modulation temp range to the room temp + zone temp interlock offset and determine how fast it should be running as the temps go up and down when compared to the sensors directly linked to the exhaust fan. See “Modulation” information later in Exhaust Fan Settings for an example.

Min CFM - Default set by factory

- Select value between 25 and “Max CFM”
- This value is utilized to help determine supply fan speed (only utilized if a supply fan is being controlled by panel) using a formula. Depending on the supply fan setting “Supply Control”, this formula changes. See “Supply Control” in the supply fan settings for formula information.

Max CFM - Default set by factory

- Select value between “Min CFM” and 65,000
- This value is utilized to help determine supply fan speed (only utilized if a supply fan is being controlled by panel) using a formula. Depending on the supply fan setting “Supply Control”, this formula changes. See “Supply Control” in the supply fan settings for formula information.

Modulation Temp Range - Default is 30°F

- This set point is only visible and configurable for VAV panel types
- Select value between 5°F and 50°F
- This value is utilized for VAV only. When fan is on, this determines how fast or slow the exhaust fan speed runs. The system needs to look at the highest hood temperature that is at or above the zone room temp + the zone temp interlock offset. From there, the main board looks at the modulation temp range to determine current exhaust fan CFM/VDC/frequency.

Example 1: One hood H1 (with one temp sensor T1), linked to one zone 1 (Z1) with one room sensor, linked to an exhaust fan E1. Assume settings are set as shown below:

Z1 Room Temperature: 75°F

Z1 Temp Interlock Offset: 10°F

Z1 Temp Interlock Hysteresis: 5°F

Z1 Temp Interlock Hysteresis Timer: 30 min

E1 Modulation Temp Range: 30°F

1) Exhaust Fan will automatically turn on at 75°F + 10°F = 85°F

2) Once exhaust is on due to temp interlock (see 1), if temps drop below 85°F - 5°F = 80°F and stay below it for 30 min (hysteresis timer starts as soon as temp drops below 80°F), fan will automatically shut off, assuming Auto Fan Off setting is set to “Yes”.

3) Maximum temperature = 85°F + 30°F = 115°F. So the fan will ramp up and down between Min CFM and Max CFM as the temperature changes between 85°F and 115°F. Aka, if hood temp sensor T1 is at or below 85°F, fan is running at Min CFM/Min VDC/Min Frequency. If temp sensor T1 is at or above 115°F, fan is running at Max CFM/Max VDC/Max Frequency. If temp sensor T1 is in between 85°F and 115°F, the fan will linearly ramp between the min and max settings.

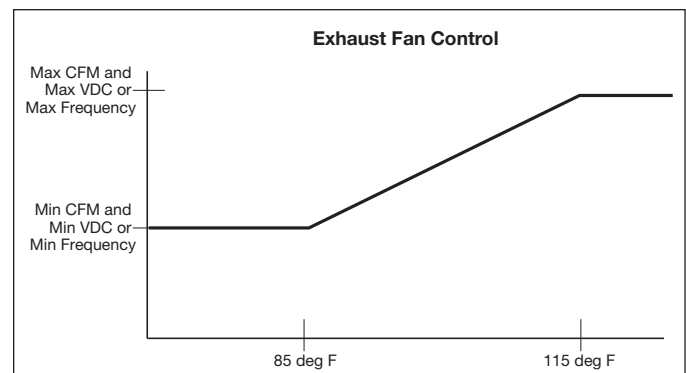

Example 2: Two hoods H1 and H2 (with two temp sensors T1 and T2 in H1 and another two temp sensors T3 and T4 in H2). Hood H1 is exhausted by exhaust fan 1 (E1) and hood H2 is exhausted by exhaust fan 2 (E2). H1 and E1 are on zone 1 (Z1), and H2 and E2 are on zone 2 (Z2). Each zone is set to a preset room temperature (no room sensors) of 77°F.

Z1 Room Temperature: Preset 77°F

Z1 Temp Interlock Offset: 10°F

Z1 Temp Interlock Hysteresis: 4°F

Z1 Temp Interlock Hysteresis Timer: 30 min

Z2 Room Temperature: Preset 77°F

Z2 Temp Interlock Offset: 15°F

Z2 Temp Interlock Hysteresis: 5°F

Z2 Temp Interlock Hysteresis Timer: 20 min

E1 Modulation Temp Range: 25°F

E2 Modulation Temp Range: 30°F

- 1) Exhaust E1 will turn on automatically when either T1 or T2 exceed $77^{\circ}\text{F} + 10^{\circ}\text{F} = 87^{\circ}\text{F}$. Exhaust E2 will turn on automatically when either T3 or T4 exceed $77^{\circ}\text{F} + 15^{\circ}\text{F} = 92^{\circ}\text{F}$.
- 2) Once turned on, exhaust E1 will not automatically shut off until both T1 and T2 temps fall to $87^{\circ}\text{F} - 4^{\circ}\text{F} = 83^{\circ}\text{F}$ for at least 30 min. Once turned on, exhaust E2 will not automatically shut off until both T3 and T4 temps fall to $92^{\circ}\text{F} - 5^{\circ}\text{F} = 87^{\circ}\text{F}$ for at least 20 min.
- 3) Once turned on, E1 will ramp between min and max CFM/VDC/Frequency between 87°F and $87^{\circ}\text{F} + 25^{\circ}\text{F} = 112^{\circ}\text{F}$ (looking at highest temp sensor reading between T1 and T2). Once turned on, E1 will ramp between min and max CFM/VDC/Frequency between 92°F and $92^{\circ}\text{F} + 30^{\circ}\text{F} = 122^{\circ}\text{F}$ (looking at highest temp sensor reading between T3 and T4)

Modbus VFD - Default set by factory

- Select from either “No” or “Yes”
- This indicates to main board that the exhaust fan is being controlled using Modbus VFD. If set to “Yes”, VFD address is set in next setting within exhaust settings.

Modbus VFD Address - Default set by factory

- This is only visible and configurable if Modbus VFD is set to “Yes” in previous setting.
- Select address between 0 and 8. Each VFD needs separate address.

Min Frequency - Default set by factory

- This setting will only appear if the system type is set to VAV and Modbus VFD is set to “Yes”.
- Select from value between 0Hz and Max Frequency
- This setting determines, during VAV applications, what the absolute minimum operating frequency of the Modbus exhaust fan VFD.

Max Frequency - Default set by factory

- This setting will only appear if Modbus VFD is set to “Yes”.
- Select from value between Min Frequency and 80Hz.
- This setting determines, for both CV and VAV applications, what the absolute maximum (or designed) operating frequency of the Modbus exhaust fan VFD to hit our designed CFM for the project.

Min VDC - Default is 5.0 VDC

- This setting will only appear if system type is set to VAV and Modbus VFD is set to “No”.
- Select from value between 0.0 VDC and “Max VDC”
- This setting determines, for VAV applications, what the absolute minimum analog output (AO) 0-10VDC is for VG fans or fans with VFDs provided by others. This helps set up the analog output lowest signal for this specific fan.

Max VDC - Default is 10.0 VDC

- This setting will only appear if a Modbus VFD is set to “No”.
- Select from value between “Min VDC” and 10.0 VDC
- This setting determines, for both CV and VAV applications, what the absolute maximum signal of the “VG” or “VFD by Others” fan. This helps set up the analog output (AO) highest signal for this specific fan.

Proving %- Default is 20%

- This setting will only appear if Fan Proving in factory settings was set to “Yes – Exh and Sup” and if the Modbus VFD setting for the specific fan was set to “Yes”.
- Select value between 1% and 100%.
 - Sets the minimum percentage of drive rated amperage that needs to be detected in order for fan to prove.



Supply Fan Settings



Settings shown below will be provided for each supply fan configured.

Fan Number - Default set by factory

- Select whole number between 0 and 8
- This allocates a specific J7 through J14 port on board to this specific fan. For example, if supply fan 1 is allocated for fan number 3, then the J9 connector (24VAC relay, 0-10VDC, and if fan providing is enabled digital input on J9 connector) will be allocated for the supply fan 1 control.

Zone - Default set by factory

- Select whole number between 0 and 8
- This links the supply fan to a specific zone. The main board already knows which zones are linked to what exhaust fans (see Exhaust Fan Settings), so if this setting links supply fans to zones, then the main board knows what exhaust fans are linked to what supply fans. This is important to determine when supply fans should turn on (aka, it is when the fans in the zone are supposed to run). This also determines what speed the supply fan should be running at based on exhaust fan design CFMs and speeds, when the panel type is VAV. See Supply Control in the supply fan settings for more information.

Min CFM - Default set by factory

- Select value between 25 and “Max CFM”
- This value is utilized to help determine supply fan speed using a formula in the case where the panel type is VAV. Depending on the supply fan setting “Supply Control”, this formula changes. See “Supply Control” for formula information.

Max CFM - Default set by factory

- Select value between “Min CFM” and 96,000
- This value is utilized to help determine supply fan speed using a formula in the case where the panel type is VAV. Depending on the supply fan setting “Supply Control”, this formula changes. See “Supply Control” for formula information.

Supply Control - Default is “Average Exh Fan Speeds”

- This setting is only visible and configurable for VAV panel types
- Select either “Average Exh Fan Speeds” or “Exh/Sup CFM Differential”

- This helps determine the specific supply fan speed based on exhaust fan speeds linked to the same zone for VAV panel types. See examples below.

Example 1: Setting is set for “Average Exh Fan Speeds”. Two exhaust fans and one supply fan linked to a common zone. All fans are non-Modbus VFDs.

E1 Min CFM: 1500 CFM

E1 Max CFM: 3000 CFM

E1 Min VDC: 4 VDC (at 1500 CFM, E1 will be at 4VDC)

E1 Max VDC: 10 VDC (at 3000 CFM, E1 will be at 10VDC)

E2 Min CFM: 400 CFM

E2 Max CFM: 1000 CFM

E2 Min VDC: 5 VDC (at 400 CFM, E2 will be at 5VDC)

E2 Max VDC: 9 VDC (at 1000 CFM, E2 will be at 9VDC)

S1 Min CFM: 1600 CFM

S1 Max CFM: 3200 CFM

S1 Min VDC: 0 VDC (at 1600 CFM, S1 will be at 0VDC)

S1 Max VDC: 10 VDC (at 3200 CFM, S1 will be at 10VDC)

E1 Currently operating at 1800 CFM (5.2VDC)

E2 Currently operating at 900 CFM (8.333VDC)

Average = (E1 Current CFM + E2 Current CFM) / Total Exh CFM = (1800 + 900) / (3000 + 1000) = 0.675.

S1 Current Supply CFM = 3200 * 0.67 = 2010 CFM.

Since 2010 is greater than 1600 CFM, we can use **2010 CFM**.

Therefore, current S1 VDC is calculated by the following:

$$Y = MX + B$$

$$M = (10 - 0) / (3200 - 1600) = 0.00625$$

$$B = 10 - 0.00625 * 3200 = -10$$

$$\text{Current S1 VDC} = M(X) + B = 0.00625 * 2010 + -10 = \mathbf{2.563 \text{ VDC}}$$

Example 2: Setting is set for “Exh/Sup CFM Differential”. Three exhaust fans and one supply fan linked to a common zone. All fans are Modbus VFDs.

E1 Min CFM: 1500 CFM

E1 Max CFM: 3000 CFM

E1 Min Hz: 30 Hz (at 1500 CFM, E1 will be at 30Hz)

E1 Max Hz: 60 Hz (at 3000 CFM, E1 will be at 60Hz)

E2 Min CFM: 250 CFM

E2 Max CFM: 500 CFM

E2 Min Hz: 30 Hz (at 250 CFM, E2 will be at 30Hz)

E2 Max Hz: 60 Hz (at 500 CFM, E2 will be at 60Hz)

E3 Min CFM: 850 CFM
E3 Max CFM: 1700 CFM
E3 Min Hz: 30 Hz (at 850 CFM, E3 will be at 30Hz)
E3 Max Hz: 75 Hz (at 1700 CFM, E3 will be at 75Hz)
S1 Min CFM: 2340 CFM
S1 Max CFM: 4680 CFM
S1 Min Hz: 45 Hz (at 2340 CFM, S1 will be at 45Hz)
S1 Max Hz: 60 Hz (at 4680 CFM, S1 will be at 60Hz)

E1 Currently operating at 2250 CFM (45Hz)
E2 Currently operating at 500 CFM (60Hz)
E3 Currently operating at 850 CFM (30Hz)

Total Exhaust CFM = 5200
Total Supply CFM = 4680
Exh/Sup Differential = 5200 - 4680 = 520
Must try to keep differential between exhaust and supply equal to 520 CFM.

Current total operating exhaust =
 $2250 + 500 + 850 = 3600$

Therefore, operate supply fan at
 $3600 - 520 = \mathbf{3080\ CFM}$.

Therefore, current S1 Hz is calculated by the following:

$$Y = MX + B$$

$$M = (60 - 45) / (4680 - 2340) = 0.00641$$

$$B = 60 - 0.00641 * 4680 = 30$$

$$\text{Current S1 Hz} = M(X) + B = \\ 0.00641 * 3080 + 30 = \mathbf{49.744\ Hz}$$

Modbus VFD - Default set by factory

- Select from either “No” or “Yes”
- This indicates to main board that the supply fan is being controlled using Modbus VFD. If set to “Yes”, VFD address is set in next setting within supply settings.

Modbus VFD Address - Default set by factory

- This is only visible and configurable if Modbus VFD is set to “Yes” in previous setting.
- Select address between 0 and 8. Each VFD needs separate address.

Min Frequency - Default set by factory

- This setting will only appear if the system type is set to VAV and Modbus VFD is set to “Yes”.
- Select from value between 0Hz and Max Frequency
- This setting determines, during VAV applications, what the absolute minimum operating frequency of the Modbus supply fan VFD. See the note after the supply CFM calculation shown previous for more information.

Max Frequency - Default set by factory

- This setting will only appear if Modbus VFD is set to “Yes”.
- Select from value between Min Frequency and 80Hz.
- This setting determines, for both CV and VAV applications, what the absolute maximum (or designed) operating frequency of the Modbus supply fan VFD to hit our designed CFM for the project.

Min VDC - Default is 5.0 VDC

- This setting will only appear if system type is set to VAV and Modbus VFD is set to “No”.
- Select from value between 0.0 VDC and “Max VDC”
- This setting determines, for VAV applications, what the absolute minimum analog signal is for VG fans or fans with VFDs provided by others. This helps set up the analog output lowest signal for this specific fan. See the note after the supply CFM calculation shown previous for more information.

Max VDC - Default is 10.0 VDC

- This setting will only appear if Modbus VFD is set to “No”.
- Select from value between “Min VDC” and 10.0 VDC
- This setting determines, for both CV and VAV applications, what the absolute maximum or designed operating signal of the “VG” or “VFD by Others” fan. This helps set up the analog output (AO) highest signal for this specific fan.

Proving %- Default is 20%

- This setting will only appear if Fan Proving in factory settings was set to “Yes – Supply Only” or “Yes - Exh and Sup” and if the Modbus VFD setting for the specific fan was set to “No”.
- Select value between 1% and 100%.
 - Sets the minimum percentage of drive rated amperage that needs to be detected in order for fan to prove.



Sensor Settings

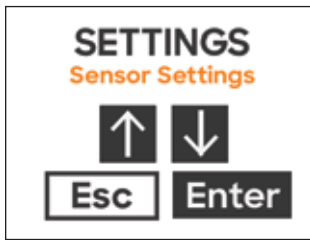

Settings shown below will be provided for each hood temp sensor configured, MB-TS1 – MB-TS8

Hood Assignment - Default set by factory

- Select a hood to link to each main board (MB) temp sensor.
- This links a specific sensor input on the main board to a specific hood.
- This helps determine when fan assigned to the same zone should be on due to cooking being detected, and also helps determine what speed a fan should be running at in VAV type systems as the hoods (and therefore the hood sensors) are also directly linked to exhaust fans to determine fan speed.

User Interface Settings

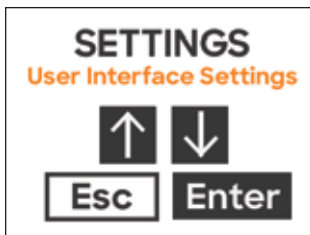

Settings shown below will be shown for single main board user interface (MB-UI)

Fan & Light Buttons - Default set by factory

- Select either “Show Both (Separate)”, “Show Fans Only”, “Show Lights Only”, “Show Both (Combined)”, or “Show None”.
- This adjusts what buttons populate on the main screens on the UI

Fan Control Zone - Default is “All Zones”

- Select from either “All Zones”, or a specific zone configured on the system
- This helps configure the main board UI fan button to determine what zone or zones it’s controlling.

Light Control - Default is “Main Board”

- Only selection available is “Main Board”
- This sets what light circuit the UI Lights button is controlling.

Buzzer - Default is “Enabled”

- Select from either “Enabled” or “Disabled”
- This enables/disables the 80 dBA UI buzzer, which sound while any fault is present and during gas reset.

General Settings

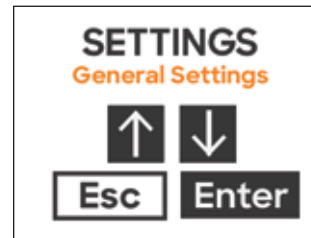

Language - Default is “English”

- Select from either “English”, “Spanish”, or “French”
 - Selecting one of these will adjust language on all screens to the selected language.

Temperature Units - Default is “Fahrenheit”

- Select from either “Fahrenheit” or “Celsius”
 - Selecting one of these will convert all temperature values and units to degrees Fahrenheit or degrees Celsius

UI Dimming Delay - Default is 10 minutes

- Select whole number from 1 to 60 minutes.
 - This sets the time from when the user interface is last touched to when the touchscreen escapes to the main screen and slightly dims to save power and screen life

Calibrate Display

- This starts calibration of the UI touchscreen
- Upon entering into this, the calibration process involves pressing firmly on the displayed crosshairs a total of 4 times, with the crosshairs in new positions on the screen each time. Upon passing calibration, screen will show “CALIBRATED”.

Date & Time

- Screens to adjust date and time
- After setting time zone (also in general settings), date and time can be further adjusted with these screens.

Time Zone

- Select a time zone based on installation location
- Most common time zones include:
 - Hawaii Standard Time
 - Alaska Daylight Savings Time
 - Pacific Daylight Savings Time
 - Arizona Mountain Standard Time
 - Mountain Daylight Savings Time
 - Central Daylight Savings Time
 - Eastern Daylight Savings Time

- This adjusts for daylight savings time depending on what area of the country the panel is installed.

NOTE

Date & Time and Time Zone affect on/off settings for fan scheduler. Before setting up fan scheduler (if utilized), make sure time zone and date/time are correct.

Hi Temp Fault Set point - Default is 210°F

- Select whole number between 120 and 250°F
 - See High Temp Fault in factory settings for details

Freeze Protect Set point - Default is 40°F

- Select whole number between 32 and 70°F
 - See Freeze Protection in factory settings for details

Auto Fan Off - Default is "Yes"

- Select from either "No" or "Yes"
 - If set to "Yes", when temperatures from hood sensors exceed room temp plus temperature interlock offset, and fans turn on, once hood temps drop below temperature interlock offset minus temp interlock hysteresis for the hysteresis timer, fans will automatically shut off.
 - If set to "No", fans need to be manually shut off, regardless of whether they once exceeded temp interlock offset or not, once temps are below temperature interlock offset minus temp interlock hysteresis for the hysteresis timer.

Service Password - Default is 1000

- Select whole number from 0000 to 9999.
- This sets up the password to access settings from the user interface.

Fan Scheduling



Fan Scheduling Enable - Default is 1000

- Select from either "No" or "Yes"
 - Selecting "Yes" will allow all fan scheduling to be used
 - Selecting "No" will hide and disengage all fan schedules. It will also clear all existing fan schedules (changes On and Off times back to "Disabled".)

Schedule Setup - All default On Times and Off Times will be "Disabled"

- This is used to adjust on and off times for each day of the week for each zone. Upon internal clock reaching a set on time, all fans in the configured zone will turn on. Upon internal clock reaching a set off time, all fans in the zone will turn off (unless temperature in hoods above temp interlock offset or fire has occurred).

Fan Scheduling Process:

Fan Scheduling → Select Zone → Select Day of Week → Select "On Time" or "Off Time" → Select time and press "Enter" to store.

Fire/Fault Settings



Fault Contact - Default is "Shunt Trip (Fire)"

- This configures C1/NO1/NC1 (and if applicable, C2/NO2/NC2) dry fire contacts
- Select from either "Shunt Trip (Fire)", "High Temp Fault" or "System Fault".
 - Selecting "Shunt Trip (Fire)" will switch relay state during fire fault (if normally closed fire switch wired to digital input terminals FS-C and FS-NC opens) or if power loss to the panel.
 - Selecting "High Temp Fault" will switch relay state during high temp fault (if high temp fault is set to "Yes", and any hood temperature rise above high temp fault set point) or if power loss to the panel.
 - Selecting "System Fault" will switch relay state if any fault occurs on system or if power loss to the panel.

NOTE

If "Shunt Follows Fans" setting is set to "Yes", fault contact will react differently. See "Shunt Follows Fans" for more information.

Exhaust During Fire - Default set by factory

- Select from either "Max", "Off", or "Continue"
 - If set to "Max" and fire fault occurs, all exhaust fans on system will turn on, and for VAV type systems, ramp to full speed immediately.
 - If set to "Off" and fire fault occurs, all exhaust fans on system will turn off
 - If set to "Continue", all exhaust fans will continue in whatever state they were in before the fire fault was triggered.



Supply During Fire - *Default set by factory*

- Select from either “Max”, “Off”, or “Continue”
 - If set to “Max” and fire fault occurs, all supply fans on system will turn on, and for VAV type systems, ramp to full speed immediately.
 - If set to “Off” and fire fault occurs, all supply fans on system will turn off
 - If set to “Continue”, all supply fans will continue in whatever state they were in before the fire fault was triggered.

Lights During Fire - *Default set by factory*

- Select from either “Off” or “Continue”
 - If set to “Off” and fire fault occurs, hood lights immediately be forced off.
 - If set to “Continue”, all hood light outputs will continue in whatever state they were in before the fire fault was triggered.

Shunt Follows Fans - *Default is “No”*

- Only applicable if fault contact was set to “Shunt Trip (Fire)”
- Select from either “No” or “Yes”
 - If set to “Yes”, fault contacts will change state (normally-open contact will close and normally-closed will open) not only during fire, but also when exhaust fans are off (in zone 1). This setting only applies to the exhaust fan or fans in zone 1 only (for example, if two zones and zone 2 fans shut off, fault contact would not change state).
 - If set to “No”, fault contact will operate as normal, stated in fault contact section.

Gas Valve Follows Fans - *Default is “No”*

- Only applicable if Gas Reset was set to “Yes” in factory settings.
- Select from either “No” or “Yes”
 - If set to “Yes”, gas valve relay output GV-H and GV-N will de-energize whenever the fans are off and, when hoods are back on in zone 1, requires user to press the gas reset button on the user interface to close and allow gas to flow to cooking equipment. It’s intended to prevent gas cooking equipment to run when the fans are off, which is required in certain jurisdictions.

Diagnostics

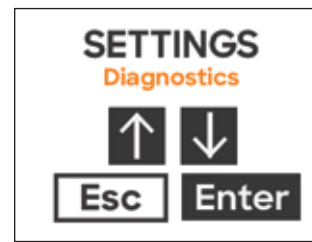

Software Version

- Provides “Main Board Version” and “UI Board Version” information currently on the system

Temp Sensors

- Able to view all room sensors and temp sensor values connected to main board
 - Main board room sensor should be called out as RS
 - Main board hood temp sensors should be called out as TSx (x being sensor number on main board)

Current Faults

- Able to view and cycle through all current faults.
- If no faults exist, message showing “No Current Faults” should appear when entering into this setting.

Fault Log

- This displays all previous faults with date and time stamps, up to 100 max. After 100 are stored, it should start re-writing the oldest ones.
- Each fault in fault logged gets its own screen on the user interface. Cycle through logged faults using up and down arrows.

Fan Status

- Displays the status (on or off), CFM, and fan VDC/VFD frequency (if applicable) for each fan.
- Each fan gets its own status screen on the user interface. Cycle through each fan using up and down arrows.

Fan Override

- Select from either “No” or “Yes”.
- Selecting “Yes” will turn on all fans in all zones for 60 min, or until set back to “No”, whichever comes first.

Fan Proving



Start Calibration

- This menu is only visible if Fan Proving is set to “Yes – Supply Only” or “Yes – Exh and Sup” in factory settings
- Select the zone to start the fan proving calibration first, then select Enter for start calibration
- Once started, “Calibrating” will appear on the screen. Fan Calibration runs through starting fans (at minimum speed, if system is VAV type) and detects whether fans have proven they are operating for 90 seconds. If passing calibration for that specific zone, screen will display “Successful”. If any fan in the zone fails to prove, after 90 seconds the screen will display “Unsuccessful”

Fan Calibration Process:

Fan Proving → Select Zone → Enter on “Start Calibration”

Digital Input Settings

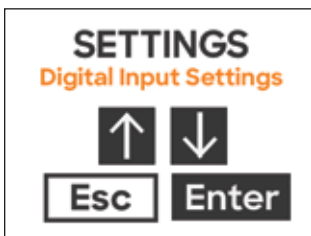

This menu allows users to adjust tasks/configuration for the 2 digital inputs on main board, aka DI-1A/DI-1B and DI-2A/DI-2B.

- Defaults are:
 - Digital Input 1: All Fans Enable
 - Digital Input 2: All Lights Enable

Page 14 shows all available Digital Input Control Options.

NOTE

These inputs work in parallel with your Fans button. If digital input is configured for enabling fans, then both Fans button and digital input have to be off in order for fans to shut off.

Adjusting Digital Input:

Digital Input Settings → Select Digital Input 1 or Digital Input 2 → Adjust value for digital input and press “Enter” to store.

BMS Settings



Modbus Address - Default is 1, visible only if BMS is configured for Modbus or BACnet IP

- This menu is used to adjust address of main board on the BMS network
- Select value between 0 and 127
- If configured for BACnet IP, Modbus Address should be set at 1

Baud Rate - Default is 9600

- This menu is used to adjust baud rate of the Modbus / BACnet communication
- Select from either 2400, 4800, 9600, 19200, 38400, 57600, 76800, or 115200 if configured for Modbus
- Select from either 9600, 19200, 38400, 57600, or 115200 if configured for BACnet MSTP
- If configured for BACnet IP, Baud Rate should be set at 9600

Device Instance - Default is 77000, visible only if BMS is configured for BACnet MSTP

- This menu is used to adjust Device Instance (Device ID) of the main board on the BMS network
- Select value between 0 and 4194303

MAC Address - Default is 0, visible only if BMS is configured for BACnet MSTP

- This menu is used to adjust MAC address of main board on the BMS network
- Select value between 0 and 127

Max Master - Default is 127, visible only if BMS is configured for BACnet MSTP

- This menu is used to adjust Max Master on the BMS network
- Select value between 0 and 127

Max Info Frames - Default is 20, visible only if BMS is configured for BACnet MSTP

- This menu is used to adjust Max Info Frames on the BMS network (time in ms)
- Select value between 0 and 255

NOTE

If panel is configured for BACnet IP, it will be provided with a gateway (GW1) to convert Modbus RTU information to BACnet IP. If configured with BACnet IP, leave Modbus Address at 1, and Baud Rate at 9600. For adjusting BACnet IP settings like IP Address, see page 39 for information.



Sequence of Operation

Normal Operation

1. Press “Fans” button on user interface to turn on fans for a specific zone (manual mode)
 - a. Kitchen Controls will turn on all exhaust and supply fans.
 - b. If configured for constant volume (CV), the system turns on the fans and operates them at maximum speeds determined by Max VDC / Max Frequency settings.
 - c. If configured for variable volume (VAV), the system starts fans at idle speeds determined by Min VDC / Min Frequency settings. If hood temperature sensor(s) detect a temperature that reaches the room temperature (determined by Preset Room Temp set point or actual room sensor) plus Temp Interlock Offset set point, the kitchen control panel records this as our base temperature, and our fan speeds will start to increase. If temperatures increase to this base temperature plus Modulation temp range, fans will be operating at maximum speeds (Max VDC / Max Frequency). Fans will vary speed accordingly as hood temperatures vary between this Modulation temp range.
 - d. If configured for variable volume (VAV) and directly controlling a supply fan, the system will adjust the supply speed based on a weighted average of the exhaust fan speeds (default).
2. Press “Fans” button on user interface again to turn off the fans.
 - a. The kitchen controls will not shut off the fans if currently operating in temp interlock mode (see 3.a – 3.c.)
3. Temperature interlock mode (automatic mode).
 - a. If hood temperature sensor(s) detect a temperature that reaches the room temperature plus Temp Interlock Offset set point, the kitchen control panel records this as our base temperature and automatically start the fans for that specific zone.
 - b. If hood temperature drops below this recorded base temperature minus Temp Interlock Hysteresis set point and the fans are not turned on manually, then the fans will shut off after the Hysteresis Timer expires(*if Auto Fan Off is set to Yes*).
 - c. If the fans were turned on manually and the user attempts to turn off the fans with the hood temperature not meeting condition b the fan(s) will remain on until such conditions are met.
4. With the fan(s) on via manual or auto mode, if the panel is configured for VAV, pressing the Max Fan button on the user interface will force exhaust fan(s) that are currently on to full speed for the Max Fan Time. The supply fan will adjust speed the same as 1.d.

5. Pressing the Max Fan button will turn the Max Fan operation off and return the fans to the speed as discussed in 1.c.
6. Press “Lights” button on user interface will turn on hood lights
7. Pressing “Lights” button again will turn off hood lights.
8. If equipped, pressing the Gas Reset button on the user interface will open the electric gas valve to allow gas to flow to the cooking equipment. Once gas has been reset it cannot be manually shut off by this button. It will remain on until a fault condition such as high temperature or fire is detected, or the power is cycled to the panel.

WARNING

Make sure after resetting gas valve that all standing pilots (if present) are lit. Failing to relight pilots will cause gas to flow into kitchen.

Fire Operation (Fire Detected)

1. With the fire system switch normally-closed contact wired to FS-C and FS-NC on the main board, and the fire system in the “fired” state, the following will occur:
 - a. System alarm will appear on keypad or touch screen
 - b. System will force the exhaust fan(s) to maximum speed (default – can be adjusted in Fire/Fault Settings)
 - c. System will force the supply fan(s) off (default – can be adjusted in Fire/Fault Settings)
 - d. System will switch fault contacts state to trip field-supplied shunt trip breakers or appliance contactors if using fault contacts.
 - e. System will force the lights off (default – can be adjusted in the Fire/Fault Settings)
 - f. If equipped, system will force the gas valve off

Fault Operation

Upon any system fault, “FAULT” will replace date/time at the bottom of the main screen, and if buzzer is enabled, sound the buzzer on the UI. Once the fault is corrected, the faults (outside of fan proving faults) will automatically clear and “FAULT” will disappear from UI. A list of all faults are shown below:

1. Fire detected
2. High Temp
 - a. System will switch fault contacts state to trip field-supplied shunt trip breakers or appliance contactors if using fault contacts.
 - b. If equipped, system will force the gas valve off
3. Freeze Protection
 - a. Associated fan(s) in that zone will be forced on (and to max speed, if VAV) until the fault is rectified.
4. Fan (J4 DI)
5. VFD Alarm

- 6. VFD Communication
- 7. Temp Sensor Error
 - a. Associated fan(s) in that zone will be forced on (and to max speed, if VAV) until the fault is rectified.
- 8. Sup. Fan Not Proving
 - a. Requires manual reset to allow fan operation to continue
- 9. Sup. Fan Proving Loss
 - a. Requires manual reset to allow fan operation to continue
- 10. Exh. Fan Not Proving
 - a. Requires manual reset to allow fan operation to continue
- 11. Exh. Fan Proving Loss
 - a. Requires manual reset to allow fan operation to continue
- 12. Proving Calib. Failed

System Optimization

NOTE

This applies to variable volume system types only.

With variable volume systems, the goal is to save energy by reducing fan speeds during non-peak cooking times. Performing a system optimization will dial in your temperature set points to provide the best performance possible based on your cooking line up.

It is suggested to perform a system optimization for each individual zone separately.

If the optimized zone is not using a room sensor:

1. With all cooking equipment turned and fans turned off, navigate into System Settings → Diagnostics → Temp Sensors → Main Board. Record your highest TSx temp sensor value assigned to the zone you are optimizing here:

(A) *Highest hood temp sensor value (no cooking):*
_____ °F

2. Escape out of Diagnostics submenu and enter into Zone Settings. Navigate to your specific zone and adjust your Preset room temp to be this recorded temperature.
3. Turn on fans and turn on all cooking equipment (on highest setting). Allow the cooking equipment lineup to safely reach maximum cooking temperatures.
4. Navigate into System Settings → Diagnostics → Temp Sensors → Main Board. Record your highest TSx temp sensor value assigned to the zone you are optimizing.

(B) *Highest hood temp sensor value (maximum cooking):* _____ °F

5. Calculate your modulation temp range using the formula below:

(B) _____ - (A) _____ - 10°F =
_____ °F

6. Escape out of Diagnostics submenu and enter into Exhaust Fan Settings. Navigate to each exhaust fan assigned to the specific zone you are testing, and adjust your Modulation Temp Range to equal the value calculated in step 5.

If the optimized zone is using a room sensor:

1. With all cooking equipment turned and fans turned off, navigate into System Settings → Diagnostics → Temp Sensors → Main Board. Record your highest RS room sensor value here:

(A) *Room sensor value:* _____ °F

2. Escape out of Diagnostics submenu and enter into Zone Settings.
3. Turn on fans and turn on all cooking equipment (on highest setting). Allow the cooking equipment lineup to safely reach maximum cooking temperatures.
4. Navigate into System Settings → Diagnostics → Temp Sensors → Main Board. Record your highest TSx temp sensor value assigned to the zone you are optimizing.



(B) Highest hood temp sensor value (maximum cooking): _____ °F

5. Calculate your modulation temp range using the formula below:

$$(B) \text{ _____ } - (A) \text{ _____ } - 10^{\circ}F = \text{ _____ } ^{\circ}F$$

6. Escape out of Diagnostics submenu and enter into Exhaust Fan Settings. Navigate to each exhaust fan assigned to the specific zone you are testing, and adjust your Modulation Temp Range to equal the value calculated in step 5.

Maintenance

WARNING

Do not perform maintenance on this control panel until all electrical power is shut off to the panel.

1. Control enclosure should be kept clean from dust, dirt, grease and debris. Clean exterior surfaces with a mild detergent and polish with a high-grade stainless steel polish to preserve the original luster.
2. Gently wipe user interface with moist rag to clean.

NOTE

Never use abrasive cleaners or chemicals on stainless steel surfaces or user interface. Never use chlorine-based cleaners or iron wool pads. They may scratch or mar the material, allowing pitting and rust to form. Always rub with the grain of the stainless when cleaning.

3. Routinely check grease temp sensors located in capture area of hood, or behind filters inside the exhaust collar. Keep these clean for proper temperature readings. Clean using rag and mild detergent or degreaser.
4. Control enclosure door must be kept closed after any maintenance to prevent electrical shock.

For control enclosures with cooling fans:

NOTE

Failure to replace cabinet fan filter can lead to poor ventilation and VFDs may overheat and fault/fail. If cabinet fan filter is failed to be replaced VFDs and VFDs overheat, replacements will not be covered under warranty.

5. Monthly check cabinet fan filter for dirt and debris by removing black plastic cover from top of unit. If filter is dirty, clean or replace. Five spare filters will ship with the unit. They will ship with control panel in a pocket on the inside - right side of the panel. Otherwise, replacement pack of 5 filters is PN: 484315.
6. Make sure cabinet fan is operating when fans are on.

Troubleshooting

Problem: Smoke spilling out of hood(s) at 100% operation

Maximum fan speed has been reduced – VAV Only	Increase exhaust fan Max VDC or Max Frequency
---	---

Belt loose or broken	Inspect/replace belt
----------------------	----------------------

Improper hood design	Check hood overhang, cross drafts and correct make-up air
----------------------	---

Problem: Smoke spilling out of hood(s) at lowest speeds – VAV only

Fan minimum speed is set too low	Increase exhaust fan Min VDC or Min Frequency
----------------------------------	---

Improper hood design	Check hood overhang, cross drafts and correct make-up air
----------------------	---

Problem: Fans do not turn up to maximum speed when cooking at highest capacity – VAV only

Dirty temperature sensor(s)	Clean grease from temperature sensor(s)
-----------------------------	---

The zone Temp Interlock Offset set point set too high	Decrease the Temp Interlock Offset set point
---	--

Preset Room Temp is set too high	Decrease the Preset Room Temp
----------------------------------	-------------------------------

Room sensor placed too close to the cooking equipment	Move room sensor away from cooking
---	------------------------------------

Fan modulation range is set too high	Decrease modulation range value
--------------------------------------	---------------------------------

Problem: Fans do not turn down to minimum speed with low/no cooking – VAV only

Dirty temperature sensor(s)	Clean grease from temperature sensor(s)
-----------------------------	---

The zone Temp Interlock Offset set point set too low	Increase the Temp Interlock Offset set point
--	--

Preset Room Temp is set too low	Increase the Preset Room Temp
---------------------------------	-------------------------------

Room sensor placed too close to the cold environment	Move room sensor away from freezer/cooler doors
--	---

Fan modulation range is set too low	Increase modulation range value
-------------------------------------	---------------------------------

Problem: Exhaust fan on and supply fan off

Belt loose or broken in supply fan	Inspect/replace belt
------------------------------------	----------------------

Fire Detected fault present	Check fire suppression switch connection
-----------------------------	--

Exhaust fan VFD in local control “mode”	Put exhaust fan VFD back into remote control “mode”
---	---

Supply fan breaker tripped	Reset breaker
----------------------------	---------------

Problem: Supply fan on and exhaust fan off

Belt loose or broken in exhaust fan	Inspect/replace belt
-------------------------------------	----------------------

Supply fan VFD in local control “mode”	Put supply fan VFD back into remote control “mode”
--	--

Supply fan breaker tripped	Reset breaker
----------------------------	---------------

Problem: Fan wheel rotates in wrong direction

VFD output wiring incorrect	Switch any two leads on the output side of the VFD (to the fan motor) OR change parameter b1-14 from 00 to 01 on the VFD.
-----------------------------	---

Problem: Max Fan does not increase fan speeds – VAV only

Exhaust already at 100% speed due to hood temperature	Proper operation
---	------------------

Problem: Fans button is on, but fans do not turn on

Broken fan belt	
-----------------	--

VFD/Motor Starter fault	Check VFDs for faults Replace fan belt
-------------------------	--

Breakers for fan(s) off	Reset breaker(s)
-------------------------	------------------



Troubleshooting

Problem: Fans button is on, and when pressed will not shut off the fans (stays ON)	
Problem: Fans button is on, and when pressed will not shut off the fans (stays ON)	Cooking temperatures detected, causing fans to stay on until cooking temperature subside. Check Diagnostics settings → Temp Sensors to see sensor temperatures
Digital input set for fan enable is closed	Check digital inputs, unwire digital input to troubleshoot
Fan scheduler set to turn on the fan	Proper operation. Disable scheduler if fans should not be operating at specific time.
Fan Override set to on	Check Diagnostics settings → Fan Override and change if display says “Turn Off”.
BMS is overriding fans on	Proper operation. Check BMS if fans should not be operating at specific time.
Freeze Protection Fault	Check to see why temperatures below near freezing. Or adjust freeze protect set point or disable freeze protection
High Temp Fault	Check to see why temperatures are being detected in the hood at very high temperatures. Or adjust high temp set point or disable high temp fault
Temp Sensor Error Fault	Check temp sensors and clean / replace if necessary. Access Diagnostics settings → Temp Sensors to see which sensors are in fault.
Problem: Fans do not turn on automatically	
Dirty temperature sensor(s)	Clean grease from temperature sensor(s)
The zone Temp Interlock Offset set point set too high	Decrease the Temp Interlock Offset set point
Preset Room Temp is set too high	Decrease the Preset Room Temp
Room sensor placed too close to the cooking equipment	Move room sensor away from cooking equipment
Problem: Fire Detected Fault	
Kitchen fire is in progress; fire suppression has dumped	Evacuate the facility immediately and contact your local fire department.
Fire system switch is in the fired position	Check the fire suppression switch connections
Problem: Temp Sensor Error	
Dirty temperature sensor(s)	Clean grease from temperature sensor(s)
Incorrect main board configuration	Check the temperature sensor settings (consult factory)
Faulty wiring to temperature sensor(s)	Check wiring at control panel and at hood connection / room sensor
Problem: Exhaust / supply VFD fault - general	
Look at the VFD for fault identification	Refer to the Yaskawa Quick Start Guide for fault and tips to correct. Once corrected, recycle power to the VFD via the breaker. Wait until all power is drained from the VFD before turning power back on.
Problem: Exhaust/supply VFD Alarm fault. Fault code “CE” or “CALL”	
Fault communication connection between VFD(s) and controller	Check all communication wiring between VFD and main board. Confirm all wiring corresponds with wiring diagram.
Incorrect programming on VFD(s)	Check VFD communication parameters
Incorrect main board configuration	Check exhaust/supply fan Modbus VFD address settings (consult factory)
Problem: Fan is making grinding/ noise and/or appears to struggle to operate	
Carrier frequency on VFD needs adjustment	Change parameter C6-02 on the VFD between 01 and 06, testing the fan at maximum speed with each adjustment. Set this parameter at whichever value corrects this issue.
Issue with fan bearings/drive components	Check fan bearings and fan drive components. Replace is necessary.
Problem: User Interface dimly lit	
No button presses detected for UI Dimming Delay time	Normal operation. Press anywhere on the screen and screen should be bright

Troubleshooting

Problem: User Interface completely blank

User interface not plugged into the correct port on main board	Confirm user interface connected to J15 port on main board
User interface cable fault	Replace user interface CAT5 cable
No power to main board	See “Control board and user interface not lit/functioning” for further troubleshooting.

Problem: “FAULT” showing at bottom of main screen

Press on FAULT button to display current faults	Diagnose issues and fix based on faults displayed
---	---

Problem: Control board and user interface not lit/functioning

Test for voltage (115VAC or 230VAC) between H1 and N1 with voltmeter. If voltage no present, then panel is not receiving power.	Check wiring and breaker feeding panel
If voltage between H1 and N1, but not getting 24VAC to main board, check TR1 transformer breaker switch (if present)	Reset transformer TR1 breaker switch if tripped.
Bad fuse on board (see F1)	Remove and test main board fuse (F1) and replace if not getting continuity through fuse. Spare fuse will ship with control panel in a picket on the inside – right side of panel.

Variable Frequency Drive (VFD) Information

Yaskawa V1000 (200-230 VAC and 460 VAC) or Yaskawa A1000 (575 VAC) variable frequency drives (VFDs) will be provided if the panel is configured to use VFDs to control the fans. These drives will come programmed from the factory, and little to no adjustment will be necessary in most cases. For more in-depth information on wiring and programming these drives, please utilize the Quick Start Guide provided with the package. This quick start guide and other technical manuals can also be found on the Yaskawa website at www.yaskawa.com.



Parameter	Description	Default Value	Factory Adjustment
b1-01	Reference Source Speed Control Method	01	02
b1-02	Run Source – Start/Stop Control Method	01	02
b1-07	LOCAL/REMOTE Run Selection	00	01
b1-17	Run Command at Power Up	00	01
C1-01	Acceleration Time 1	10.00 seconds	30.00 seconds
C1-02	Deceleration Time 1	10.00 seconds	30.00 seconds
E1-01	Input Voltage	Dependent on drive type	Dependent on motor voltage*
E1-04	Max Output Frequency	60Hz	Dependent on motor max frequency
E1-06	Base Frequency	60Hz	Dependent on motor max frequency
E2-01	Motor Rated Current	Dependent on drive type	Dependent on motor FLA (full load amperage)*
H5-01	Drive Node Address	1F	Dependent on VFD address*
H5-02	Communication Speed Selection	03	04
H5-09	CE Detection Time	2.0 seconds	10.0 seconds
L2-01	Momentary Power Loss Operation Selection	00	02
L5-01	Number of Auto Restart Attempts	00	10

*See wiring diagram for more information.

Resetting the VFD Faults

Upon a VFD fault, first determine the cause of the fault and correct. Typically, if the drive detects a fault, it will remain inoperable until that fault has been corrected and the drive has been reset.

Once a fault has been corrected, the easiest way to clear the displayed fault on the VFD is to shut off power to the drive from the power source (breaker). Wait for the VFD to fully discharge and then restore the power.

Upon correcting a minor fault, recycling power may not be necessary. Simply press , then press  twice.

Once the fault has been corrected and the drive has been reset, the main controller alarm should automatically be cleared.



BACnet IP Network Information

For panels configured for BACnet IP, the panel will be provided with a ProSoft® Modbus RTU to BACnet IP QuickServer Gateway.

Main board should be configured for Modbus (RTU), with an address of 1 and a baud rate of 9600.

To adjust IP Network settings, you must access the web configuration by connecting a computer to the Ethernet port of the gateway. Ethernet port shown below:



The computer used must be assigned to a static IP address of 192.168.2.xxx and a subnet mask of 255.255.255.0. To do this for Windows 10:

- Find the search field in the local computer's taskbar (usually to the right of the windows icon) and type in "Control Panel".
- Click "Control Panel" and then click "Network and Sharing Center".
- Click "Change adapter settings" on the left side of the window.
- Right-click on "Local Area Connection" and select "Properties" from the dropdown menu.
- Highlight [Internet Protocol Version 4 \(TCP/IPv4\)](#) and then click the Properties button.
- Select and enter a static IP address on the same subnet as the gateway. For example:

Use the following IP address:

IP address:	<input type="text" value="192 . 168 . 2 . 102"/>
Subnet mask:	<input type="text" value="255 . 255 . 255 . 0"/>
Default gateway:	<input type="text" value=" . . ."/>

- Click the Okay button to close the Internet Protocol window and the Close button to close the Ethernet Properties window.

To access the web configuration, type the IP address of the gateway (default is 192.168.2.101) into the URL field of any web browser. The window shown below should appear. Click "Setup", then "Network Settings". Here you can update the IP address to whatever is required for the BMS. After updating, click the "Update IP Settings" button. The screen will then prompt you for a System Restart. Click the "System Restart" button found at the bottom of the page.



NOTE

Any time the IP address is updated, you will need to type the new IP address on the URL to gain access to the web configuration.

BMS Modbus (RTU) Points List

BMS Modbus MB Connector: J23

Stop bits: 1

Data bits: 8

Parity: None

Object Name	Register Type	Register No.	Read(R) Write(W)	Data Type	Description
HR_BMS_RS_TEMP_F	Holding Register	40001	R	Analog	Room Temperature Sensor
HR_BMS_TS1_TEMP_F	Holding Register	40002	R	Analog	Hood Temperature Sensor 1
HR_BMS_TS2_TEMP_F	Holding Register	40003	R	Analog	Hood Temperature Sensor 2
HR_BMS_TS3_TEMP_F	Holding Register	40004	R	Analog	Hood Temperature Sensor 3
HR_BMS_TS4_TEMP_F	Holding Register	40005	R	Analog	Hood Temperature Sensor 4
HR_BMS_TS5_TEMP_F	Holding Register	40006	R	Analog	Hood Temperature Sensor 5
HR_BMS_TS6_TEMP_F	Holding Register	40007	R	Analog	Hood Temperature Sensor 6
HR_BMS_TS7_TEMP_F	Holding Register	40008	R	Analog	Hood Temperature Sensor 7
HR_BMS_TS8_TEMP_F	Holding Register	40009	R	Analog	Hood Temperature Sensor 8
HR_BMS_E1_OP_PERCENT	Holding Register	40010	R	Analog	Exhaust fan 1 Operating Percentage
HR_BMS_E2_OP_PERCENT	Holding Register	40011	R	Analog	Exhaust fan 2 Operating Percentage
HR_BMS_E3_OP_PERCENT	Holding Register	40012	R	Analog	Exhaust fan 3 Operating Percentage
HR_BMS_E4_OP_PERCENT	Holding Register	40013	R	Analog	Exhaust fan 4 Operating Percentage
HR_BMS_E5_OP_PERCENT	Holding Register	40014	R	Analog	Exhaust fan 5 Operating Percentage
HR_BMS_E6_OP_PERCENT	Holding Register	40015	R	Analog	Exhaust fan 6 Operating Percentage
HR_BMS_E7_OP_PERCENT	Holding Register	40016	R	Analog	Exhaust fan 7 Operating Percentage
HR_BMS_E8_OP_PERCENT	Holding Register	40017	R	Analog	Exhaust fan 8 Operating Percentage
HR_BMS_S1_OP_PERCENT	Holding Register	40018	R	Analog	Supply fan 1 Operating Percentage
HR_BMS_S2_OP_PERCENT	Holding Register	40019	R	Analog	Supply fan 2 Operating Percentage
HR_BMS_S3_OP_PERCENT	Holding Register	40020	R	Analog	Supply fan 3 Operating Percentage
HR_BMS_S4_OP_PERCENT	Holding Register	40021	R	Analog	Supply fan 4 Operating Percentage
HR_BMS_E1_VFD_OP_FREQ	Holding Register	40022	R	Analog	Exhaust fan 1 VFD Operating Frequency
HR_BMS_E2_VFD_OP_FREQ	Holding Register	40023	R	Analog	Exhaust fan 2 VFD Operating Frequency
HR_BMS_E3_VFD_OP_FREQ	Holding Register	40024	R	Analog	Exhaust fan 3 VFD Operating Frequency
HR_BMS_E4_VFD_OP_FREQ	Holding Register	40025	R	Analog	Exhaust fan 4 VFD Operating Frequency
HR_BMS_E5_VFD_OP_FREQ	Holding Register	40026	R	Analog	Exhaust fan 5 VFD Operating Frequency
HR_BMS_E6_VFD_OP_FREQ	Holding Register	40027	R	Analog	Exhaust fan 6 VFD Operating Frequency
HR_BMS_E7_VFD_OP_FREQ	Holding Register	40028	R	Analog	Exhaust fan 7 VFD Operating Frequency
HR_BMS_E8_VFD_OP_FREQ	Holding Register	40029	R	Analog	Exhaust fan 8 VFD Operating Frequency
HR_BMS_S1_VFD_OP_FREQ	Holding Register	40030	R	Analog	Supply Fan 1 VFD Operating Frequency
HR_BMS_S2_VFD_OP_FREQ	Holding Register	40031	R	Analog	Supply Fan 2 VFD Operating Frequency
HR_BMS_S3_VFD_OP_FREQ	Holding Register	40032	R	Analog	Supply Fan 3 VFD Operating Frequency
HR_BMS_S4_VFD_OP_FREQ	Holding Register	40033	R	Analog	Supply Fan 4 VFD Operating Frequency
HR_BMS_E1_VFD_OP_AMP	Holding Register	40034	R	Analog	Exhaust Fan 1 VFD Operating Amperage
HR_BMS_E2_VFD_OP_AMP	Holding Register	40035	R	Analog	Exhaust Fan 2 VFD Operating Amperage
HR_BMS_E3_VFD_OP_AMP	Holding Register	40036	R	Analog	Exhaust fan 3 VFD Operating Amperage
HR_BMS_E4_VFD_OP_AMP	Holding Register	40037	R	Analog	Exhaust fan 4 VFD Operating Amperage
HR_BMS_E5_VFD_OP_AMP	Holding Register	40038	R	Analog	Exhaust fan 5 VFD Operating Amperage
HR_BMS_E6_VFD_OP_AMP	Holding Register	40039	R	Analog	Exhaust fan 6 VFD Operating Amperage
HR_BMS_E7_VFD_OP_AMP	Holding Register	40040	R	Analog	Exhaust fan 7 VFD Operating Amperage
HR_BMS_E8_VFD_OP_AMP	Holding Register	40041	R	Analog	Exhaust fan 8 VFD Operating Amperage
HR_BMS_S1_VFD_OP_AMP	Holding Register	40042	R	Analog	Supply Fan 1 VFD Operating Amperage
HR_BMS_S2_VFD_OP_AMP	Holding Register	40043	R	Analog	Supply Fan 2 VFD Operating Amperage
HR_BMS_S3_VFD_OP_AMP	Holding Register	40044	R	Analog	Supply Fan 3 VFD Operating Amperage
HR_BMS_S4_VFD_OP_AMP	Holding Register	40045	R	Analog	Supply Fan 4 VFD Operating Amperage
HR_BMS_E1_VFD_OUTPUT_PWR	Holding Register	40046	R	Analog	Exhaust Fan 1 VFD Output Power
HR_BMS_E2_VFD_OUTPUT_PWR	Holding Register	40047	R	Analog	Exhaust Fan 2 VFD Output Power
HR_BMS_E3_VFD_OUTPUT_PWR	Holding Register	40048	R	Analog	Exhaust Fan 3 VFD Output Power



BMS Modbus (RTU) Points List - Continued

Object Name	Register Type	Register No.	Read(R) Write(W)	Data Type	Description
HR_BMS_E4_VFD_OUTPUT_PWR	Holding Register	40049	R	Analog	Exhaust Fan 4 VFD Output Power
HR_BMS_E5_VFD_OUTPUT_PWR	Holding Register	40050	R	Analog	Exhaust Fan 5 VFD Output Power
HR_BMS_E6_VFD_OUTPUT_PWR	Holding Register	40051	R	Analog	Exhaust Fan 6 VFD Output Power
HR_BMS_E7_VFD_OUTPUT_PWR	Holding Register	40052	R	Analog	Exhaust Fan 7 VFD Output Power
HR_BMS_E8_VFD_OUTPUT_PWR	Holding Register	40053	R	Analog	Exhaust Fan 8 VFD Output Power
HR_BMS_S1_VFD_OUTPUT_PWR	Holding Register	40054	R	Analog	Supply Fan 1 VFD Output Power
HR_BMS_S2_VFD_OUTPUT_PWR	Holding Register	40055	R	Analog	Supply Fan 2 VFD Output Power
HR_BMS_S3_VFD_OUTPUT_PWR	Holding Register	40056	R	Analog	Supply Fan 3 VFD Output Power
HR_BMS_S4_VFD_OUTPUT_PWR	Holding Register	40057	R	Analog	Supply Fan 4 VFD Output Power
HR_BMS_E1_VFD_FAULTS	Holding Register	40058	R	Binary	Exhaust Fan 1 VFD Fault (vfd reg 32 bit3)
HR_BMS_E2_VFD_FAULTS	Holding Register	40059	R	Binary	Exhaust Fan 2 VFD Fault (vfd reg 32 bit3)
HR_BMS_E3_VFD_FAULTS	Holding Register	40060	R	Binary	Exhaust Fan 3 VFD Fault (vfd reg 32 bit3)
HR_BMS_E4_VFD_FAULTS	Holding Register	40061	R	Binary	Exhaust Fan 4 VFD Fault (vfd reg 32 bit3)
HR_BMS_E5_VFD_FAULTS	Holding Register	40062	R	Binary	Exhaust Fan 5 VFD Fault (vfd reg 32 bit3)
HR_BMS_E6_VFD_FAULTS	Holding Register	40063	R	Binary	Exhaust Fan 6 VFD Fault (vfd reg 32 bit3)
HR_BMS_E7_VFD_FAULTS	Holding Register	40064	R	Binary	Exhaust Fan 7 VFD Fault (vfd reg 32 bit3)
HR_BMS_E8_VFD_FAULTS	Holding Register	40065	R	Binary	Exhaust Fan 8 VFD Fault (vfd reg 32 bit3)
HR_BMS_S1_VFD_FAULTS	Holding Register	40066	R	Binary	Supply Fan 1 VFD Fault (vfd reg 32 bit3)
HR_BMS_S2_VFD_FAULTS	Holding Register	40067	R	Binary	Supply Fan 2 VFD Fault (vfd reg 32 bit3)
HR_BMS_S3_VFD_FAULTS	Holding Register	40068	R	Binary	Supply Fan 3 VFD Fault (vfd reg 32 bit3)
HR_BMS_S4_VFD_FAULTS	Holding Register	40069	R	Binary	Supply Fan 4 VFD Fault (vfd reg 32 bit3)
HR_BMS_RELAY_J7_STATUS	Holding Register	40070	R	Binary	Fan Relay 1 Status (J7 digital output)
HR_BMS_RELAY_J8_STATUS	Holding Register	40071	R	Binary	Fan Relay 2 Status (J8 digital output)
HR_BMS_RELAY_J9_STATUS	Holding Register	40072	R	Binary	Fan Relay 3 Status (J9 digital output)
HR_BMS_RELAY_J10_STATUS	Holding Register	40073	R	Binary	Fan Relay 4 Status (J10 digital output)
HR_BMS_RELAY_J11_STATUS	Holding Register	40074	R	Binary	Fan Relay 5 Status (J11 digital output)
HR_BMS_RELAY_J12_STATUS	Holding Register	40075	R	Binary	Fan Relay 6 Status (J12 digital output)
HR_BMS_RELAY_J13_STATUS	Holding Register	40076	R	Binary	Fan Relay 7 Status (J13 digital output)
HR_BMS_RELAY_J14_STATUS	Holding Register	40077	R	Binary	Fan Relay 8 Status (J14 digital output)
HR_BMS_GLOBAL_FAULT	Holding Register	40078	R	Binary	Any System Faults
HR_BMS_FIRE_DETECTED	Holding Register	40079	R	Binary	Fire Detected
HR_BMS_SFAN_PROVING_FAULT	Holding Register	40080	R	Binary	Supply Fan Proving Fault
HR_BMS_SFAN_LOSS_FAULT	Holding Register	40081	R	Binary	Supply Fan Loss Fault
HR_BMS_EFAN_PROVING_FAULT	Holding Register	40082	R	Binary	Exhaust Fan Proving Fault
HR_BMS_EFAN_LOSS_FAULT	Holding Register	40083	R	Binary	Exhaust Fan Loss Fault
HR_BMS_HIGH_TEMP_FAULT	Holding Register	40084	R	Binary	High Temperature Fault
HR_BMS_FRZ_PROTECT_FAULT	Holding Register	40085	R	Binary	Freeze Protection Fault
HR_BMS_FAN_J4DI_FAULT	Holding Register	40086	R	Binary	J4 DI Fan Fault
HR_BMS_VFD_ALARM_FAULT	Holding Register	40087	R	Binary	VFD Alarm Fault
HR_BMS_VFD_COMM_FAULT	Holding Register	40088	R	Binary	VFD Communication Fault
HR_BMS_PRV_CALIB_FAILED	Holding Register	40089	R	Binary	Proving Calibration Failed
HR_BMS_TEMP_SENSOR_FAULT	Holding Register	40090	R	Binary	Temperature Sensor Error
HR_BMS_Z1_ON_BY_TEMP	Holding Register	40091	R	Binary	Zone 1 was turned on by temperature
HR_BMS_Z1_ON_BY_UI	Holding Register	40092	R	Binary	Zone 1 was turned on by UI button
HR_BMS_Z1_ON_BY_DI	Holding Register	40093	R	Binary	Zone 1 was turned on by DI switch
HR_BMS_Z1_ON_BY_BMS	Holding Register	40094	R	Binary	Zone 1 was turned on by BMS
HR_BMS_Z2_ON_BY_TEMP	Holding Register	40095	R	Binary	Zone 2 was turned on by temperature
HR_BMS_Z2_ON_BY_UI	Holding Register	40096	R	Binary	Zone 2 was turned on by UI button
HR_BMS_Z2_ON_BY_DI	Holding Register	40097	R	Binary	Zone 2 was turned on by DI switch
HR_BMS_Z2_ON_BY_BMS	Holding Register	40098	R	Binary	Zone 2 was turned on by BMS



BMS Modbus (RTU) Points List - Continued

Object Name	Register Type	Register No.	Read(R) Write(W)	Data Type	Description
HR_BMS_Z3_ON_BY_TEMP	Holding Register	40099	R	Binary	Zone 3 was turned on by temperature
HR_BMS_Z3_ON_BY_UI	Holding Register	40100	R	Binary	Zone 3 was turned on by UI button
HR_BMS_Z3_ON_BY_DI	Holding Register	40101	R	Binary	Zone 3 was turned on by DI switch
HR_BMS_Z3_ON_BY_BMS	Holding Register	40102	R	Binary	Zone 3 was turned on by BMS
HR_BMS_Z4_ON_BY_TEMP	Holding Register	40103	R	Binary	Zone 4 was turned on by temperature
HR_BMS_Z4_ON_BY_UI	Holding Register	40104	R	Binary	Zone 4 was turned on by UI button
HR_BMS_Z4_ON_BY_DI	Holding Register	40105	R	Binary	Zone 4 was turned on by DI switch
HR_BMS_Z4_ON_BY_BMS	Holding Register	40106	R	Binary	Zone 4 was turned on by BMS
HR_BMS_Z5_ON_BY_TEMP	Holding Register	40107	R	Binary	Zone 5 was turned on by temperature
HR_BMS_Z5_ON_BY_UI	Holding Register	40108	R	Binary	Zone 5 was turned on by UI button
HR_BMS_Z5_ON_BY_DI	Holding Register	40109	R	Binary	Zone 5 was turned on by DI switch
HR_BMS_Z5_ON_BY_BMS	Holding Register	40110	R	Binary	Zone 5 was turned on by BMS
HR_BMS_Z6_ON_BY_TEMP	Holding Register	40111	R	Binary	Zone 6 was turned on by temperature
HR_BMS_Z6_ON_BY_UI	Holding Register	40112	R	Binary	Zone 6 was turned on by UI button
HR_BMS_Z6_ON_BY_DI	Holding Register	40113	R	Binary	Zone 6 was turned on by DI switch
HR_BMS_Z6_ON_BY_BMS	Holding Register	40114	R	Binary	Zone 6 was turned on by BMS
HR_BMS_Z7_ON_BY_TEMP	Holding Register	40115	R	Binary	Zone 7 was turned on by temperature
HR_BMS_Z7_ON_BY_UI	Holding Register	40116	R	Binary	Zone 7 was turned on by UI button
HR_BMS_Z7_ON_BY_DI	Holding Register	40117	R	Binary	Zone 7 was turned on by DI switch
HR_BMS_Z7_ON_BY_BMS	Holding Register	40118	R	Binary	Zone 7 was turned on by BMS
HR_BMS_Z8_ON_BY_TEMP	Holding Register	40119	R	Binary	Zone 8 was turned on by temperature
HR_BMS_Z8_ON_BY_UI	Holding Register	40120	R	Binary	Zone 8 was turned on by UI button
HR_BMS_Z8_ON_BY_DI	Holding Register	40121	R	Binary	Zone 8 was turned on by DI switch
HR_BMS_Z8_ON_BY_BMS	Holding Register	40122	R	Binary	Zone 8 was turned on by BMS
HR_BMS_LT_ON_BY_UI	Holding Register	40123	R	Binary	Lights on by UI button
HR_BMS_LT_ON_BY_DI	Holding Register	40124	R	Binary	Lights on by DI switch
HR_BMS_LT_ON_BY_BMS	Holding Register	40125	R	Binary	Lights on by BMS
HR_BMS_ZONE1_ON	Holding Register	40126	R/W	Binary	1/0 to turn on/off zone 1
HR_BMS_ZONE2_ON	Holding Register	40127	R/W	Binary	1/0 to turn on/off zone 2
HR_BMS_ZONE3_ON	Holding Register	40128	R/W	Binary	1/0 to turn on/off zone 3
HR_BMS_ZONE4_ON	Holding Register	40129	R/W	Binary	1/0 to turn on/off zone 4
HR_BMS_ZONE5_ON	Holding Register	40130	R/W	Binary	1/0 to turn on/off zone 5
HR_BMS_ZONE6_ON	Holding Register	40131	R/W	Binary	1/0 to turn on/off zone 6
HR_BMS_ZONE7_ON	Holding Register	40132	R/W	Binary	1/0 to turn on/off zone 7
HR_BMS_ZONE8_ON	Holding Register	40133	R/W	Binary	1/0 to turn on/off zone 8
HR_BMS_HD_LIGHT_ON	Holding Register	40134	R/W	Binary	1/0 to turn on /off lights
HR_BMS_MAX_FAN_ENA	Holding Register	40135	R/W	Binary	1/0 to turn MaxAir on/off
HR_BMS_E1_ENABLE	Holding Register	40136	R/W	Binary	1/0 to turn on/off Exhaust Fan 1
HR_BMS_E2_ENABLE	Holding Register	40137	R/W	Binary	1/0 to turn on/off Exhaust Fan 2
HR_BMS_E3_ENABLE	Holding Register	40138	R/W	Binary	1/0 to turn on/off Exhaust Fan 3
HR_BMS_E4_ENABLE	Holding Register	40139	R/W	Binary	1/0 to turn on/off Exhaust Fan 4
HR_BMS_E5_ENABLE	Holding Register	40140	R/W	Binary	1/0 to turn on/off Exhaust Fan 5
HR_BMS_E6_ENABLE	Holding Register	40141	R/W	Binary	1/0 to turn on/off Exhaust Fan 6
HR_BMS_E7_ENABLE	Holding Register	40142	R/W	Binary	1/0 to turn on/off Exhaust Fan 7
HR_BMS_E8_ENABLE	Holding Register	40143	R/W	Binary	1/0 to turn on/off Exhaust Fan 8
HR_BMS_S1_ENABLE	Holding Register	40144	R/W	Binary	1/0 to turn on /off Supply Fan 1
HR_BMS_S2_ENABLE	Holding Register	40145	R/W	Binary	1/0 to turn on /off Supply Fan 2
HR_BMS_S3_ENABLE	Holding Register	40146	R/W	Binary	1/0 to turn on /off Supply Fan 3
HR_BMS_S4_ENABLE	Holding Register	40147	R/W	Binary	1/0 to turn on /off Supply Fan 4



BACnet Points List

BACnet MSTP MB Connector: J23

BACnet IP Gateway: GW1

BACnet Device Instance: 77000 (Default)

Object Name: Kitchen Hood Controls

BACnet MSTP Vendor Identifier: 1159

BACnet MSTP Vendor Name: Greenheck/Accurex

Object Name	BACnet Type	Object ID	Read(R) Write(W)	Description	Units
Room Sensor Temp	Analog Input (AI)	0	R	Room Temperature Sensor	Degrees Fahrenheit
Hood Sensor 1 Temp	Analog Input (AI)	1	R	Hood Temperature Sensor 1	Degrees Fahrenheit
Hood Sensor 2 Temp	Analog Input (AI)	2	R	Hood Temperature Sensor 2	Degrees Fahrenheit
Hood Sensor 3 Temp	Analog Input (AI)	3	R	Hood Temperature Sensor 3	Degrees Fahrenheit
Hood Sensor 4 Temp	Analog Input (AI)	4	R	Hood Temperature Sensor 4	Degrees Fahrenheit
Hood Sensor 5 Temp	Analog Input (AI)	5	R	Hood Temperature Sensor 5	Degrees Fahrenheit
Hood Sensor 6 Temp	Analog Input (AI)	6	R	Hood Temperature Sensor 6	Degrees Fahrenheit
Hood Sensor 7 Temp	Analog Input (AI)	7	R	Hood Temperature Sensor 7	Degrees Fahrenheit
Hood Sensor 8 Temp	Analog Input (AI)	8	R	Hood Temperature Sensor 8	Degrees Fahrenheit
Operating % - Exhaust Fan 1	Analog Input (AI)	9	R	Exhaust fan 1 Operating Percentage	Percent
Operating % - Exhaust Fan 2	Analog Input (AI)	10	R	Exhaust fan 2 Operating Percentage	Percent
Operating % - Exhaust Fan 3	Analog Input (AI)	11	R	Exhaust fan 3 Operating Percentage	Percent
Operating % - Exhaust Fan 4	Analog Input (AI)	12	R	Exhaust fan 4 Operating Percentage	Percent
Operating % - Exhaust Fan 5	Analog Input (AI)	13	R	Exhaust fan 5 Operating Percentage	Percent
Operating % - Exhaust Fan 6	Analog Input (AI)	14	R	Exhaust fan 6 Operating Percentage	Percent
Operating % - Exhaust Fan 7	Analog Input (AI)	15	R	Exhaust fan 7 Operating Percentage	Percent
Operating % - Exhaust Fan 8	Analog Input (AI)	16	R	Exhaust fan 8 Operating Percentage	Percent
Operating % - Supply Fan 1	Analog Input (AI)	17	R	Supply fan 1 Operating Percentage	Percent
Operating % - Supply Fan 2	Analog Input (AI)	18	R	Supply fan 2 Operating Percentage	Percent
Operating % - Supply Fan 3	Analog Input (AI)	19	R	Supply fan 3 Operating Percentage	Percent
Operating % - Supply Fan 4	Analog Input (AI)	20	R	Supply fan 4 Operating Percentage	Percent
VFD Operating Frequency - Exhaust Fan 1	Analog Input (AI)	21	R	Exhaust fan 1 VFD Operating Frequency	Hertz
VFD Operating Frequency - Exhaust Fan 2	Analog Input (AI)	22	R	Exhaust fan 2 VFD Operating Frequency	Hertz
VFD Operating Frequency - Exhaust Fan 3	Analog Input (AI)	23	R	Exhaust fan 3 VFD Operating Frequency	Hertz
VFD Operating Frequency - Exhaust Fan 4	Analog Input (AI)	24	R	Exhaust fan 4 VFD Operating Frequency	Hertz
VFD Operating Frequency - Exhaust Fan 5	Analog Input (AI)	25	R	Exhaust fan 5 VFD Operating Frequency	Hertz
VFD Operating Frequency - Exhaust Fan 6	Analog Input (AI)	26	R	Exhaust fan 6 VFD Operating Frequency	Hertz
VFD Operating Frequency - Exhaust Fan 7	Analog Input (AI)	27	R	Exhaust fan 7 VFD Operating Frequency	Hertz
VFD Operating Frequency - Exhaust Fan 8	Analog Input (AI)	28	R	Exhaust fan 8 VFD Operating Frequency	Hertz
VFD Operating Frequency - Supply Fan 1	Analog Input (AI)	29	R	Supply Fan 1 VFD Operating Frequency	Hertz
VFD Operating Frequency - Supply Fan 2	Analog Input (AI)	30	R	Supply Fan 2 VFD Operating Frequency	Hertz
VFD Operating Frequency - Supply Fan 3	Analog Input (AI)	31	R	Supply Fan 3 VFD Operating Frequency	Hertz
VFD Operating Frequency - Supply Fan 4	Analog Input (AI)	32	R	Supply Fan 4 VFD Operating Frequency	Hertz
VFD Operating Amperage - Exhaust Fan 1	Analog Input (AI)	33	R	Exhaust Fan 1 VFD Operating Amperage	Amperes
VFD Operating Amperage - Exhaust Fan 2	Analog Input (AI)	34	R	Exhaust Fan 2 VFD Operating Amperage	Amperes

BACnet Points List - Continued

Object Name	BACnet Type	Object ID	Read(R) Write(W)	Description	Units
VFD Operating Amperage - Exhaust Fan 3	Analog Input (AI)	35	R	Exhaust fan 3 VFD Operating Amperage	Amperes
VFD Operating Amperage - Exhaust Fan 4	Analog Input (AI)	36	R	Exhaust fan 4 VFD Operating Amperage	Amperes
VFD Operating Amperage - Exhaust Fan 5	Analog Input (AI)	37	R	Exhaust fan 5 VFD Operating Amperage	Amperes
VFD Operating Amperage - Exhaust Fan 6	Analog Input (AI)	38	R	Exhaust fan 6 VFD Operating Amperage	Amperes
VFD Operating Amperage - Exhaust Fan 7	Analog Input (AI)	39	R	Exhaust fan 7 VFD Operating Amperage	Amperes
VFD Operating Amperage - Exhaust Fan 8	Analog Input (AI)	40	R	Exhaust fan 8 VFD Operating Amperage	Amperes
VFD Operating Amperage - Supply Fan 1	Analog Input (AI)	41	R	Supply Fan 1 VFD Operating Amperage	Amperes
VFD Operating Amperage - Supply Fan 2	Analog Input (AI)	42	R	Supply Fan 2 VFD Operating Amperage	Amperes
VFD Operating Amperage - Supply Fan 3	Analog Input (AI)	43	R	Supply Fan 3 VFD Operating Amperage	Amperes
VFD Operating Amperage - Supply Fan 4	Analog Input (AI)	44	R	Supply Fan 4 VFD Operating Amperage	Amperes
VFD Power Output - Exhaust Fan 1	Analog Input (AI)	45	R	Exhaust Fan 1 VFD Output Power	Watts
VFD Power Output - Exhaust Fan 2	Analog Input (AI)	46	R	Exhaust Fan 2 VFD Output Power	Watts
VFD Power Output - Exhaust Fan 3	Analog Input (AI)	47	R	Exhaust Fan 3 VFD Output Power	Watts
VFD Power Output - Exhaust Fan 4	Analog Input (AI)	48	R	Exhaust Fan 4 VFD Output Power	Watts
VFD Power Output - Exhaust Fan 5	Analog Input (AI)	49	R	Exhaust Fan 5 VFD Output Power	Watts
VFD Power Output - Exhaust Fan 6	Analog Input (AI)	50	R	Exhaust Fan 6 VFD Output Power	Watts
VFD Power Output - Exhaust Fan 7	Analog Input (AI)	51	R	Exhaust Fan 7 VFD Output Power	Watts
VFD Power Output - Exhaust Fan 8	Analog Input (AI)	52	R	Exhaust Fan 8 VFD Output Power	Watts
VFD Power Output - Supply Fan 1	Analog Input (AI)	53	R	Supply Fan 1 VFD Output Power	Watts
VFD Power Output - Supply Fan 2	Analog Input (AI)	54	R	Supply Fan 2 VFD Output Power	Watts
VFD Power Output - Supply Fan 3	Analog Input (AI)	55	R	Supply Fan 3 VFD Output Power	Watts
VFD Power Output - Supply Fan 4	Analog Input (AI)	56	R	Supply Fan 4 VFD Output Power	Watts
Fault - VFD Exhaust Fan 1	Binary Input (BI)	0	R	Exhaust Fan 1 VFD Fault (vfd reg 32 bit3)	No-Units
Fault - VFD Exhaust Fan 2	Binary Input (BI)	1	R	Exhaust Fan 2 VFD Fault (vfd reg 32 bit3)	No-Units
Fault - VFD Exhaust Fan 3	Binary Input (BI)	2	R	Exhaust Fan 3 VFD Fault (vfd reg 32 bit3)	No-Units
Fault - VFD Exhaust Fan 4	Binary Input (BI)	3	R	Exhaust Fan 4 VFD Fault (vfd reg 32 bit3)	No-Units
Fault - VFD Exhaust Fan 5	Binary Input (BI)	4	R	Exhaust Fan 5 VFD Fault (vfd reg 32 bit3)	No-Units



BACnet Points List - Continued

Object Name	BACnet Type	Object ID	Read(R) Write(W)	Description	Units
Fault - VFD Exhaust Fan 6	Binary Input (BI)	5	R	Exhaust Fan 6 VFD Fault (vfd reg 32 bit3)	No-Units
Fault - VFD Exhaust Fan 7	Binary Input (BI)	6	R	Exhaust Fan 7 VFD Fault (vfd reg 32 bit3)	No-Units
Fault - VFD Exhaust Fan 8	Binary Input (BI)	7	R	Exhaust Fan 8 VFD Fault (vfd reg 32 bit3)	No-Units
Fault - VFD Supply Fan 1	Binary Input (BI)	8	R	Supply Fan 1 VFD Fault (vfd reg 32 bit3)	No-Units
Fault - VFD Supply Fan 2	Binary Input (BI)	9	R	Supply Fan 2 VFD Fault (vfd reg 32 bit3)	No-Units
Fault - VFD Supply Fan 3	Binary Input (BI)	10	R	Supply Fan 3 VFD Fault (vfd reg 32 bit3)	No-Units
Fault - VFD Supply Fan 4	Binary Input (BI)	11	R	Supply Fan 4 VFD Fault (vfd reg 32 bit3)	No-Units
Fan Digital Output Status - Relay J7	Binary Input (BI)	12	R	Fan Relay 1 Status (J7 digital output)	No-Units
Fan Digital Output Status - Relay J8	Binary Input (BI)	13	R	Fan Relay 2 Status (J8 digital output)	No-Units
Fan Digital Output Status - Relay J9	Binary Input (BI)	14	R	Fan Relay 3 Status (J9 digital output)	No-Units
Fan Digital Output Status - Relay J10	Binary Input (BI)	15	R	Fan Relay 4 Status (J10 digital output)	No-Units
Fan Digital Output Status - Relay J11	Binary Input (BI)	16	R	Fan Relay 5 Status (J11 digital output)	No-Units
Fan Digital Output Status - Relay J12	Binary Input (BI)	17	R	Fan Relay 6 Status (J12 digital output)	No-Units
Fan Digital Output Status - Relay J13	Binary Input (BI)	18	R	Fan Relay 7 Status (J13 digital output)	No-Units
Fan Digital Output Status - Relay J14	Binary Input (BI)	19	R	Fan Relay 8 Status (J14 digital output)	No-Units
Fault - Global (Any Fault)	Binary Input (BI)	20	R	Any System Faults	No-Units
Fault - Fire Detected	Binary Input (BI)	21	R	Fire Detected	No-Units
Fault - Supply Fan Not Proving	Binary Input (BI)	22	R	Supply Fan Proving Fault	No-Units
Fault - Supply Fan Proving Loss	Binary Input (BI)	23	R	Supply Fan Loss Fault	No-Units
Fault - Exhaust Fan Not Proving	Binary Input (BI)	24	R	Exhaust Fan Proving Fault	No-Units
Fault - Exhaust Fan Proving Loss	Binary Input (BI)	25	R	Exhaust Fan Loss Fault	No-Units
Fault - High Temp	Binary Input (BI)	26	R	High Temperature Fault	No-Units
Fault - Freeze Protection	Binary Input (BI)	27	R	Freeze Protection Fault	No-Units
Fault - Fan (J4 Digital Input)	Binary Input (BI)	28	R	J4 DI Fan Fault	No-Units
Fault - VFD Alarm	Binary Input (BI)	29	R	VFD Alarm Fault	No-Units
Fault - VFD Communication	Binary Input (BI)	30	R	VFD Communication Fault	No-Units
Fault - Proving Calibration Failed	Binary Input (BI)	31	R	Proving Calibration Failed	No-Units
Fault - Temp Sensor Error	Binary Input (BI)	32	R	Temperature Sensor Error	No-Units
Zone 1 - Fans On By Temp	Binary Input (BI)	33	R	Zone 1 was turned on by temperature	No-Units
Zone 1 - Fans On By UI	Binary Input (BI)	34	R	Zone 1 was turned on by UI button	No-Units
Zone 1 - Fans On By Digital Input	Binary Input (BI)	35	R	Zone 1 was turned on by DI switch	No-Units

BACnet Points List - Continued

Object Name	BACnet Type	Object ID	Read(R) Write(W)	Description	Units
Zone 1 - Fans On By BMS	Binary Input (BI)	36	R	Zone 1 was turned on by BMS	No-Units
Zone 2 - Fans On By Temp	Binary Input (BI)	37	R	Zone 2 was turned on by temperature	No-Units
Zone 2 - Fans On By UI	Binary Input (BI)	38	R	Zone 2 was turned on by UI button	No-Units
Zone 2 - Fans On By Digital Input	Binary Input (BI)	39	R	Zone 2 was turned on by DI switch	No-Units
Zone 2 - Fans On By BMS	Binary Input (BI)	40	R	Zone 2 was turned on by BMS	No-Units
Zone 3 - Fans On By Temp	Binary Input (BI)	41	R	Zone 3 was turned on by temperature	No-Units
Zone 3 - Fans On By UI	Binary Input (BI)	42	R	Zone 3 was turned on by UI button	No-Units
Zone 3 - Fans On By Digital Input	Binary Input (BI)	43	R	Zone 3 was turned on by DI switch	No-Units
Zone 3 - Fans On By BMS	Binary Input (BI)	44	R	Zone 3 was turned on by BMS	No-Units
Zone 4 - Fans On By Temp	Binary Input (BI)	45	R	Zone 4 was turned on by temperature	No-Units
Zone 4 - Fans On By UI	Binary Input (BI)	46	R	Zone 4 was turned on by UI button	No-Units
Zone 4 - Fans On By Digital Input	Binary Input (BI)	47	R	Zone 4 was turned on by DI switch	No-Units
Zone 4 - Fans On By BMS	Binary Input (BI)	48	R	Zone 4 was turned on by BMS	No-Units
Zone 5 - Fans On By Temp	Binary Input (BI)	49	R	Zone 5 was turned on by temperature	No-Units
Zone 5 - Fans On By UI	Binary Input (BI)	50	R	Zone 5 was turned on by UI button	No-Units
Zone 5 - Fans On By Digital Input	Binary Input (BI)	51	R	Zone 5 was turned on by DI switch	No-Units
Zone 5 - Fans On By BMS	Binary Input (BI)	52	R	Zone 5 was turned on by BMS	No-Units
Zone 6 - Fans On By Temp	Binary Input (BI)	53	R	Zone 6 was turned on by temperature	No-Units
Zone 6 - Fans On By UI	Binary Input (BI)	54	R	Zone 6 was turned on by UI button	No-Units
Zone 6 - Fans On By Digital Input	Binary Input (BI)	55	R	Zone 6 was turned on by DI switch	No-Units
Zone 6 - Fans On By BMS	Binary Input (BI)	56	R	Zone 6 was turned on by BMS	No-Units
Zone 7 - Fans On By Temp	Binary Input (BI)	57	R	Zone 7 was turned on by temperature	No-Units
Zone 7 - Fans On By UI	Binary Input (BI)	58	R	Zone 7 was turned on by UI button	No-Units
Zone 7 - Fans On By Digital Input	Binary Input (BI)	59	R	Zone 7 was turned on by DI switch	No-Units
Zone 7 - Fans On By BMS	Binary Input (BI)	60	R	Zone 7 was turned on by BMS	No-Units
Zone 8 - Fans On By Temp	Binary Input (BI)	61	R	Zone 8 was turned on by temperature	No-Units
Zone 8 - Fans On By UI	Binary Input (BI)	62	R	Zone 8 was turned on by UI button	No-Units
Zone 8 - Fans On By Digital Input	Binary Input (BI)	63	R	Zone 8 was turned on by DI switch	No-Units
Zone 8 - Fans On By BMS	Binary Input (BI)	64	R	Zone 8 was turned on by BMS	No-Units
Main Board Hood Lights On By UI	Binary Input (BI)	65	R	Lights on by UI button	No-Units
Main Board Hood Lights On By DigInput	Binary Input (BI)	66	R	Lights on by DI switch	No-Units
Main Board Hood Lights On By BMS	Binary Input (BI)	67	R	Lights on by BMS	No-Units
Fans - Zone 1	Binary Output (BO)	0	R/W	1/0 to turn on/off zone 1	No-Units



BACnet Points List - Continued

Object Name	BACnet Type	Object ID	Read(R) Write(W)	Description	Units
Fans - Zone 2	Binary Output (BO)	1	R/W	1/0 to turn on/off zone 2	No-Units
Fans - Zone 3	Binary Output (BO)	2	R/W	1/0 to turn on/off zone 3	No-Units
Fans - Zone 4	Binary Output (BO)	3	R/W	1/0 to turn on/off zone 4	No-Units
Fans - Zone 5	Binary Output (BO)	4	R/W	1/0 to turn on/off zone 5	No-Units
Fans - Zone 6	Binary Output (BO)	5	R/W	1/0 to turn on/off zone 6	No-Units
Fans - Zone 7	Binary Output (BO)	6	R/W	1/0 to turn on/off zone 7	No-Units
Fans - Zone 8	Binary Output (BO)	7	R/W	1/0 to turn on/off zone 8	No-Units
Main Board Hood Lights	Binary Output (BO)	8	R/W	1/0 to turn on /off lights	No-Units
Max Fan Enable	Binary Output (BO)	9	R/W	1/0 to turn MaxAir on/off	No-Units
Exhaust Fan 1 Enable	Binary Output (BO)	10	R/W	1/0 to turn on/off Exhaust Fan 1	No-Units
Exhaust Fan 2 Enable	Binary Output (BO)	11	R/W	1/0 to turn on/off Exhaust Fan 2	No-Units
Exhaust Fan 3 Enable	Binary Output (BO)	12	R/W	1/0 to turn on/off Exhaust Fan 3	No-Units
Exhaust Fan 4 Enable	Binary Output (BO)	13	R/W	1/0 to turn on/off Exhaust Fan 4	No-Units
Exhaust Fan 5 Enable	Binary Output (BO)	14	R/W	1/0 to turn on/off Exhaust Fan 5	No-Units
Exhaust Fan 6 Enable	Binary Output (BO)	15	R/W	1/0 to turn on/off Exhaust Fan 6	No-Units
Exhaust Fan 7 Enable	Binary Output (BO)	16	R/W	1/0 to turn on/off Exhaust Fan 7	No-Units
Exhaust Fan 8 Enable	Binary Output (BO)	17	R/W	1/0 to turn on/off Exhaust Fan 8	No-Units
Supply Fan 1 Enable	Binary Output (BO)	18	R/W	1/0 to turn on /off Supply Fan 1	No-Units
Supply Fan 2 Enable	Binary Output (BO)	19	R/W	1/0 to turn on /off Supply Fan 2	No-Units
Supply Fan 3 Enable	Binary Output (BO)	20	R/W	1/0 to turn on /off Supply Fan 3	No-Units
Supply Fan 4 Enable	Binary Output (BO)	21	R/W	1/0 to turn on /off Supply Fan 4	No-Units

Main Board Connector Information

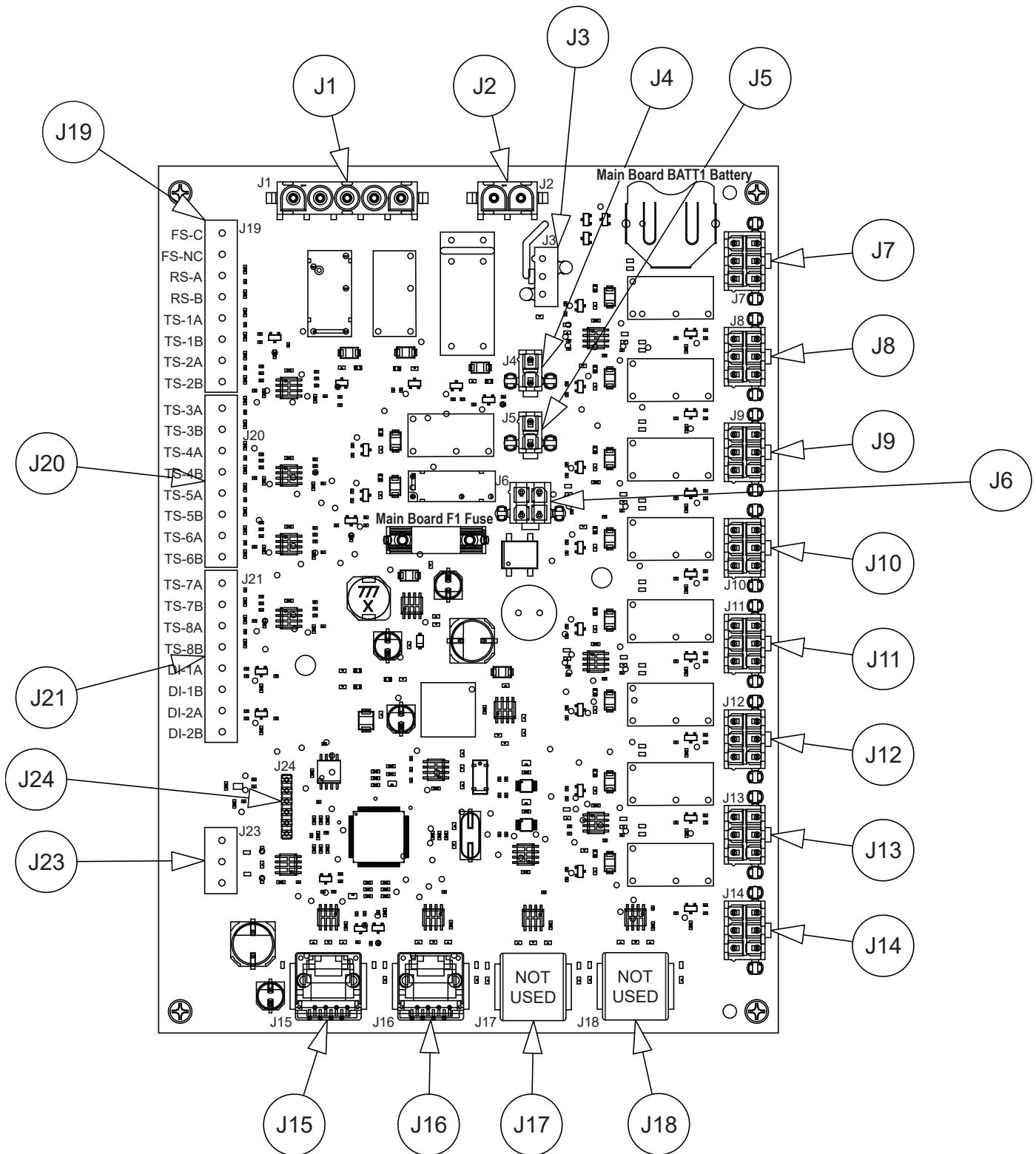

Main Board (MB) is powered off of 24VAC and protected with 2A slow blow fuse (F1).



Model ACX-386706	
Connector	Description
J1	Fault Contact and Gas Valve Connector
J2	Hood Light Relay Control Connector
J3	24 VAC Board Power and Ground Connector
J4	Fan Fault Connector (Digital Input)
J5	VFD Cooling Fan Connector (24 VAC output)
J6	Not Used
J7	Fan Connector 1 (one 0-10VDC, one 24 VAC output, and one digital input)
J8	Fan Connector 2 (one 0-10VDC, one 24 VAC output and one digital input)
J9	Fan Connector 3 (one 0-10VDC, one 24 VAC output, and one digital input)
J10	Fan Connector 4 (one 0-10VDC, one 24 VAC output, and one digital input)
J11	Fan Connector 5 (one 0-10VDC, one 24 VAC output, and one digital input)
J12	Fan Connector 6 (one 0-10VDC, one 24 VAC output, and one digital input)
J13	Fan Connector 7 (one 0-10VDC, one 24 VAC output, and one digital input)
J14	Fan Connector 8 (one 0-10VDC, one 24 VAC output, and one digital input)
J15	User Interface Connector (RJ45)
J16	Modbus VFD Connector (RJ45)
J17	Not Used (RJ45)
J18	Not Used (RJ45)
J19	Digital Inputs and PT1000 Ohm Inputs (Fire, Room Sensor, TS1, TS2) – Screw Terminals
J20	PT1000 Ohm Inputs (TS3, TS4, TS5, TS6) – Screw Terminals
J21	Digital Inputs and PT1000 Ohm Inputs (TS7, TS8, DI1, DI2) – Screw Terminals
J23	BMS Interface Connector – Screw Terminals
J24	Not Used (Factory)

Replacement Parts List

To order replacement parts, contact: parts@accurex.com, or call 1-800-371-6858.

Part Number	Description
382898	Electric Plug Knockout Seal, 0.875"
386829	End Stop
386947	Wire Harness, Fan Fault (J4)
386948	Wire Harness, Fault Only (J1)
386949	Wire Harness, Fault & Gas Valve (J1)
386950	Wire Harness, Lights (J2)
386951	Wire Harness, 24VAC Power (J3)
386952	Wire Harness, Cooling Fan (J5)
386953	Wire Harness, Fan DO (J7-J14)
386954	Wire Harness, Fan AO (J7-J14)
386955	Wire Harness, Fan DO+AO (J7-J14)
386956	Wire Harness, Fan DO+FP (J7-J14)
386957	Wire Harness, Fan AO+FP (J7-J14)
386958	Wire Harness, Fan DO+AO+FP (J7-J14)
385218	75VA 24 VAC Transformer
386914	150VA 24 VAC Transformer (use when 7 or more motor starters <= 32A FLA, or 3 or more motor starters at >32 FLA)
386919	7A Fuse for 150VA 24VAC Transformer
484162	Quarter Turn Black Latch
484163	Cam for Quarter Turn Latch
484499	Handle for Quarter Turn Latch
484164	Prison Package Keyed Latch
484165	Prison Package Latch Key
386915	24 VAC Cabinet Fan
484312	Cabinet Fan Filter Kit
484313	Cabinet Fan Inlet Guard
484315	Cabinet Fan Replacement Filters (Pack of 5 filters only)
383559	24 VAC DPDT Relay Base
383561	24VAC DPDT Relay
Contact Factory	User Interface Replacement Subassembly
Contact Factory	Ship Loose User Interface Assembly with J-Box
386815	1FT R45 CAT5 VFD Cable
386816	4FT RJ45 CAT5 User Interface/VFD Cable
Contact Factory	Replacement VFD
Contact Factory	Replacement Contactor
Contact Factory	Replacement Overload
386937	10" VFD Modbus Harness
386455	VFD Modbus 3-Way RJ45 Splitter
384906	Grounding Block (<=24A)
384913	Grounding Block (>24A)
1022214	Current Switch for fan proving operation
1022391	Ship Loose Room Sensor Assembly
1022388	Ship Loose Hood Temp Sensor Assembly
386461	50FT RJ45 CAT5 User Interface Cable
386463	100FT RJ45 CAT5 User Interface Cable
Contact Factory	Replacement Main Board Subassembly (MB)
384925	Hood Temp Sensor Only
484000	Hood Temp Sensor Compression Seal Only
387044	Fuse, Main Board 2A 5X20MM Time Delay



Maintenance Log

Date _____ Time _____ AM/PM

Notes: _____

Date _____ Time _____ AM/PM

Notes: _____

Date _____ Time _____ AM/PM

Notes: _____

Date _____ Time _____ AM/PM

Notes: _____

Date _____ Time _____ AM/PM

Notes: _____

Date _____ Time _____ AM/PM

Notes: _____

Date _____ Time _____ AM/PM

Notes: _____

Date _____ Time _____ AM/PM

Notes: _____

Date _____ Time _____ AM/PM

Notes: _____

Date _____ Time _____ AM/PM

Notes: _____

Date _____ Time _____ AM/PM

Notes: _____

Date _____ Time _____ AM/PM

Notes: _____



Maintenance Log

Date _____ Time _____ AM/PM

Notes: _____

Date _____ Time _____ AM/PM

Notes: _____

Date _____ Time _____ AM/PM

Notes: _____

Date _____ Time _____ AM/PM

Notes: _____

Date _____ Time _____ AM/PM

Notes: _____

Date _____ Time _____ AM/PM

Notes: _____

Date _____ Time _____ AM/PM

Notes: _____

Date _____ Time _____ AM/PM

Notes: _____

Our Commitment

As a result of our commitment to continuous improvement, Accurex reserves the right to change specifications without notice.

Product warranties can be found online at accurex.com, either on the specific product page or in the Warranty section of the website at Accurex.com/Resources/Warranty.



P.O. Box 410 Schofield, WI 54476
Phone: 800.333.1400 • Fax: 715.241.6191
Parts: 800.355.5354 • accurex.com