

Technical Data Sheet

Single Wall Commercial Kitchen Exhaust

SWCK

Product Line

SWCK - Single Wall Commercial Kitchen Exhaust Ductwork



Application

Stainless steel duct for connecting cooking appliances, kitchen hoods, and dishwasher exhausts to the outdoors under negative or positive pressure.

A true replacement for field welded black steel.

Design eliminates welding and lengthy inspections in the field, provides UL/ULC Listed and Certified exhaust solutions.



Purpose

Factory built eliminates welding in the field.

Easiest and Fastest joint assembly on the market using innovative and industry first technology. No V bands means faster and easier installations.

Due to the unique joint design, every pipe length can be cut-to-fit in the field, it is possible to do any project using only 48" long pipe lengths!

Assurance of finest quality and reliability.

Quick and easy inspections.

UL and ULC Listings

- UL-1978 Standard, Grease Duct (ULC-S662 Standard for Factory-Built Grease Ducts)
- UL-103 Standard, Building Heating Appliance Chimney
- Additional UL/ULC 20" W.C. Pressure Listing

Materials

- Made of all stainless steel, thickness per UL-1978 Listing
- All supports and accessories are stainless steel

Connection & Installation Details

2.2" overlapping joint with **Patent-Pending** light weight technology and double female socket permitting fastest alignment/installation on the market:

1. Use supplied silicone sealant to make the complete seal
2. Push the male/female ends together
3. Install the single-screw locking band

Features

- Only 1/16 inch per foot slope is required
- Factory CAD designs for installation ease
- All lengths are field cuttable for maximum flexibility
- 100% stainless steel with Limited Lifetime Warranty
- Overlapping high pressure joints
- Smooth flow and known resistance for perfected factory pressure calculations

Technical Data Sheet

Single Wall Commercial Kitchen Exhaust

SWCK

Product Line

SWCK - Single Wall Commercial Kitchen Exhaust Ductwork



Product Specifications

SWCK - Single Wall Commercial Kitchen Exhaust Ductwork

Diameters	6, 7, 8, 9, 10, 11, 12, 13, 14, 16, 18, 20, 22, 24, 26, 28, 30, 32, 34, & 36 (use SWFL for diameters 38" through 48")
Available Lengths	9", 12", 18", 24", 30", 36", 42", & 48" (or any fixed length between)
Available Fittings	Any elbow or tee, over 80 catalog fittings per each diameter
Available Accessories	All-stainless supports, guides, hangers, adapters - over 25 accessories per each diameter

Smart Fittings & Accessories

Besides the smart cut-to-fit technology, Jeremias uses smart fittings and accessories specifically designed for Grease Ducts; 87-degree elbow with built in access panel, 45-degree elbow with built in access panel, common wye with reduction branches, and no-weld hood connections.

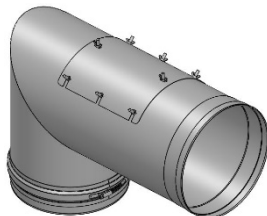

87-Degree Elbow with Access

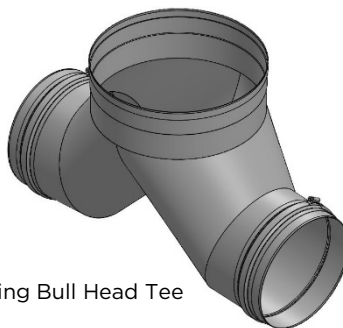

Increasing Bull Head Tee

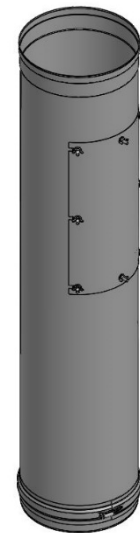

In Line Access Length

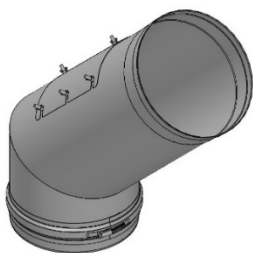

45-Degree Elbow with Access

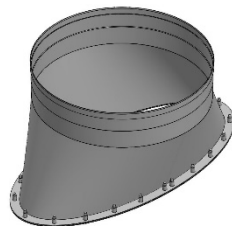

No-Weld Hood Adapter

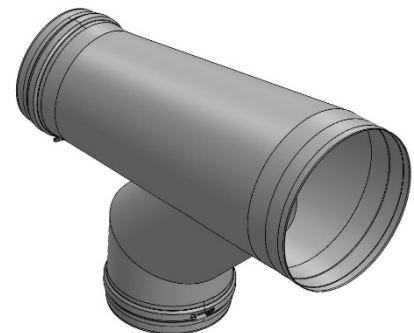

Increasing Boot Tee